

LEIF MEJLBRO

COMPLEX FUNCTIONS EXAMPLES

C-6

CALCULUS OF RESIDUES



DOWNLOAD FREE TEXTBOOKS AT
BOOKBOON.COM
NO REGISTRATION NEEDED

Leif Mejlbro

Complex Functions Examples c-6

Calculus of Residues

Complex Functions Examples c-6 – Calculus of Residues
© 2008 Leif Mejlbro & Ventus Publishing ApS
ISBN 978-87-7681-391-8

Contents

	Introduction	5
1	Rules of computation of residues	6
2	Residues in nite singularities	9
3	Line integrals computed by means of residues	33
4	The residuum at ∞	57

Please click the advert

WHAT'S MISSING IN THIS EQUATION?

You could be one of our future talents

MAERSK INTERNATIONAL TECHNOLOGY & SCIENCE PROGRAMME

Are you about to graduate as an **engineer** or **geoscientist**? Or have you already graduated?
If so, there may be an exciting future for you with A.P. Moller - Maersk.



MAERSK

www.maersk.com/mitas

Introduction

This is the sixth book containing examples from the *Theory of Complex Functions*. In this volume we shall consider the rules of calculations or residues, both in finite singularities and in ∞ . The theory heavily relies on the Laurent series from the fifth book in this series. The applications of the calculus of residues are given in the seventh book.

Even if I have tried to be careful about this text, it is impossible to avoid errors, in particular in the first edition. It is my hope that the reader will show some understanding of my situation.

Leif Mejlbro
15th June 2008

1 Rules of computation of residues

We refer in general to the following rules of computation of residues:

DEFINITION OF A RESIDUUM. Assume that $f(z)$ is an analytic function defined in a neighbourhood of $z_0 \in \mathbb{C}$ (not necessarily at z_0 itself) with the Laurent series expansion

$$f(z) = \sum_{n=-\infty}^{+\infty} a_n z^n, \quad 0 < |z| < r.$$

We define the *residuuum*, or *residue*, of $f(z)$ (more correctly of the complex differential form $f(z) dz$) as the coefficient of $1/z$ in the Laurent series, i.e.

$$\operatorname{res}(f(z) dz; z_0) = \operatorname{res}(f(z); z_0) := \frac{1}{2\pi i} \oint_{\Gamma} f(z) dz = a_{-1},$$

where Γ denotes any simple closed curve, which surrounds z_0 in positive sense, and where there is no other singularity of $f(z)$ inside and on the curve Γ .

RULE I. If $z_0 \in \mathbb{C}$ is a pole of order $\leq q$, where $q \in \mathbb{N}$, of the analytic function $f(z)$, then

$$\operatorname{res}(f; z_0) = \frac{1}{(q-1)!} \lim_{z \rightarrow z_0} \frac{d^{q-1}}{dz^{q-1}} \left\{ (z - z_0)^{q-1} f(z) \right\}.$$

Please click the advert



CHALLENGE YOURSELF

WWW.STUDYINSWEDEN.SE

Today's job market values ambitious, innovative, perceptive team players. Swedish universities foster these qualities through a forward-thinking culture where you're close to the latest ideas and global trends.

Si.
Swedish Institute

Whatever your career goals may be, studying in Sweden will give you valuable skills and a competitive advantage for your future. www.studyinsweden.se

An important special case of RULE I is

RULE IA. If z_0 is a simple pole or a removable singularity of the analytic function $f(z)$, then

$$\operatorname{res}(f; z_0) = \lim_{z \rightarrow z_0} (z - z_0) f(z).$$

RULE II. If $A(z)$ and $B(z)$ are analytic in a neighbourhood of z_0 , and $B(z)$ has a zero of first order at z_0 , then the residuum of the quotient $f(z) := A(z)/B(z)$ is given by

$$\operatorname{res}(f(z); z_0) = \operatorname{res}\left(\frac{A(z)}{B(z)}; z_0\right) = \frac{A(z_0)}{B'(z_0)}.$$

We also have the following generalization of RULE II, which however is only rarely used, because it usual implies some heavy calculations:

RULE III. Assume that $A(z)$ and $B(z)$ are both analytic in a neighbourhood of z_0 , and assume that $B(z)$ has a zero of second order. Then the residuum of the quotient $f(z) = A(z)/B(z)$ at z_0 is given by

$$\operatorname{res}(f(z); z_0) = \operatorname{res}\left(\frac{A(z)}{B(z)}; z_0\right) = \frac{6 A'(z_0) B''(z_0) - 2 A(z_0) B^{(3)}(z_0)}{3 \{B''(z_0)\}^2}.$$

The complicated structure of RULE III above indicates why it should only rarely be applied.

DEFINITION OF THE RESIDUUM AT ∞ . Assume that $f(z)$ is analytic in the set $|z| > R$, so $f(z)$ has a Laurent series expansion

$$f(z) = \sum_{n=-\infty}^{+\infty} a_n z^n.$$

We define the residuum at ∞ as

$$\operatorname{res}(f(z) dz; \infty) := -a_{-1},$$

where one should notice the change of sign.

Rule IV. Assume that $f(z)$ has a zero at ∞ . Then

$$\operatorname{res}(f dz; \infty) = - \lim_{x \rightarrow \infty} x f(x).$$

Rule V. Assume that $f(z)$ is analytic for $|z| > R$. Then

$$\operatorname{res}(f(z) dz; \infty) = -\operatorname{res}\left(\frac{1}{w^2} f\left(\frac{1}{w}\right) dw; 0\right).$$

This may be expressed in the following way: If we change the variable in the Laurent series expansion above by $z = 1/w$, then the singularity $z_0 = \infty$ is mapped into $w_0 = 0$. Since

$$-\frac{1}{w^2} dw = d\left(\frac{1}{w}\right) \quad (= dz),$$

it follows by this change of variable that we have as a *differential form*

$$\operatorname{res}(f(z) dz; \infty) = \operatorname{res}\left(f\left(\frac{1}{w}\right) d\left(\frac{1}{w}\right); w_0 = 0\right),$$

which shows that it is the *complex differential form*, which is connected with the residues.

CAUCHY'S RESIDUE THEOREM. Assume that $f(z)$ is analytic in an open domain $\Omega \subseteq \mathbb{C}$, and let Γ be a simple, closed curve in Ω , run through in its positive direction, such that there are only a finite number of singularities $\{z_1, \dots, z_k\}$ of $f(z)$ inside the curve, i.e. to the left of the curve seen in its direction. Then

$$\frac{1}{2\pi i} \oint_{\Gamma} f(z) dz = \sum_{n=1}^k \operatorname{res}(f(z); z_n).$$

SPECIAL CASE OF CAUCHY'S RESIDUE THEOREM. Assume that $f(z)$ is analytic in $\Omega = \mathbb{C} \setminus \{z_1, \dots, z_k\}$, i.e. $f(z)$ has only a finite number of singularities in \mathbb{C} . then

$$\sum_{n=1}^k \operatorname{res}(f(z); z_n) + \operatorname{res}(f(z); \infty) = 0,$$

i.e. the sum of the residues is 0.

Finally, it should be mentioned that since functions like

$$\frac{1}{\sin z}, \quad \frac{1}{\cos z}, \quad \tan z, \quad \cot z, \quad \frac{1}{\sinh z}, \quad \frac{1}{\cosh z}, \quad \tanh z, \quad \coth z,$$

etc., does *not* have ∞ as an *isolated* singularity, none of these functions has a residuum at ∞ .

2 Residues in finite singularities

Example 2.1 Find the residuum of the function $f(z) = \frac{1}{z^2(z-1)}$, $z \neq 0, 1$, at the point 0.

Then compute

$$\oint_{|z|=\frac{1}{2}} \frac{dz}{z^2(z-1)}.$$

We expand $f(z)$ into a Laurent series in the annulus $0 < |z| < 1$, i.e. in a neighbourhood of $z_0 = 0$. Then

$$f(z) = \frac{1}{z^2(z-1)} = -\frac{1}{z^2} \cdot \frac{1}{1-z} = -\frac{1}{z^2} \sum_{n=0}^{+\infty} z^n = -\frac{1}{z^2} - \frac{1}{z} - 1 - \dots - z^n - \dots.$$

The residuum is a_{-1} of this expansion, so it follows immediately that

$$\operatorname{res} \left(\frac{1}{z^2(z-1)}, 0 \right) = a_{-1} = -1.$$

Then

$$\oint_{|z|=\frac{1}{2}} \frac{dz}{z^2(z-1)} = 2\pi i \operatorname{res} \left(\frac{1}{z^2(z-1)}, 0 \right) = -2\pi i.$$

Example 2.2 Find the residuum of the function $f(z) = \frac{1}{z^{2n}(z^2-1)}$, $z \neq 0, 1$, in the point 0.

The function can be considered as a function in $w = z^2$, so the Laurent series expansion from $z_0 = 0$ only contains *even* exponents. In particular, $a_{-1} = 0$, hence

$$\operatorname{res} \left(\frac{1}{z^2(z^2-1)} \right) = a_{-1} = 0,$$

and we do not have to find the explicit Laurent series in this case.

Example 2.3 Find the residuum of the function $f(z) = \frac{\sin^2 z}{z^5}$, $z \neq 0$, at the point $z_0 = 0$.

The numerator $\sin^2 z$ has a zero of order 2, and the denominator z^5 has a zero of order 5, hence $f(z) = \frac{\sin^2 z}{z^5}$ has a pole of order 3 at $z_0 = 0$.

If we choose $q = 3$ in Rule I, we get the following expression,

$$\operatorname{rex} \left(\frac{\sin^2 z}{z^5}; 0 \right) = \frac{1}{2!} \lim_{z \rightarrow 0} \frac{d^2}{dz^2} \left\{ \frac{\sin^2 z}{z^2} \right\},$$

which will give us some unpleasant computations.

Then note that Rule I gives us the possibility to choose a larger q , which here is to our advantage. In fact, if we choose $q = 5$ in Rule I, then

$$\operatorname{res}\left(\frac{\sin^2 z}{z^5}; 0\right) = \frac{1}{4!} \lim_{z \rightarrow 0} \frac{d^4}{dz^4} \{\sin^2 z\} = \frac{1}{24} \lim_{z \rightarrow 0} \frac{d^3}{dz^3} \{\sin 2z\} = \frac{1}{24} \lim_{z \rightarrow 0} 2^3 \{-\cos 2z\} = -\frac{1}{3}.$$

Example 2.4 Find the residues at $z = 0$ of the following functions:

$$(a) \frac{z^2 + 1}{z}, \quad (b) \frac{z^2 + 3z - 5}{z^3}.$$

(a) It follows from

$$\frac{z^2 + 1}{z} = \frac{1}{z} + z,$$

that

$$\operatorname{res}(f; 0) = a_{-1} = 1.$$

Please click the advert

www.job.oticon.dk

oticon
PEOPLE FIRST

(b) It follows from

$$\frac{z^2 + 3z - 5}{z^3} = \frac{1}{z} + \frac{3}{z^2} - \frac{5}{z^3},$$

that

$$\operatorname{res}(f; 0) = a_{-1} = 1.$$

Example 2.5 Find the residues at $z = 0$ of the following functions:

$$(a) \frac{e^z}{z}, \quad (b) \frac{e^z}{z^2}, \quad (c) \frac{\sin z}{z^4}.$$

(a) Here, $z = 0$ is a simple pole, hence by RULE I,

$$\operatorname{res}(f; 0) = \lim_{z \rightarrow 0} e^z = 1.$$

(b) Here, $z = 0$ is a double pole, hence by RULE I,

$$\operatorname{res}(f; 0) = \frac{1}{1!} \lim_{z \rightarrow 0} \frac{d}{dz} e^z = \lim_{z \rightarrow 0} e^z = 1.$$

(c) We get by a series expansion of the numerator $\sin z$ that

$$\frac{\sin z}{z^4} = \frac{1}{z^4} \left\{ z - \frac{z^3}{3!} + \frac{z^5}{5!} - \cdots \right\} = \frac{1}{z^3} - \frac{1}{6} \cdot \frac{1}{z} + \frac{1}{120} \cdot z + \cdots.$$

Hence

$$\operatorname{res}\left(\frac{\sin z}{z^4}; 0\right) = a_{-1} = -\frac{1}{6}.$$

ALTERNATIVELY we apply RULE I, considering 0 as a pole of *at most* order 4 (the order is in fact $3 < 4$):

$$\operatorname{res}\left(\frac{\sin z}{z^4}; 0\right) = \frac{1}{3!} \lim_{z \rightarrow 0} \frac{d^3}{dz^3} \sin z = \frac{1}{6} \lim_{z \rightarrow 0} \{-\cos z\} = -\frac{1}{6}.$$

Example 2.6 Find the residues at $z = 0$ of the following functions:

$$(a) \frac{\sin z}{z^5}, \quad (b) \frac{\operatorname{Log}(1+z)}{z^2}.$$

(a) Here, $\frac{\sin z}{z^5}$ is an *even* function, so

$$\operatorname{res}\left(\frac{\sin z}{z^5}; 0\right) = a_{-1} = 0.$$

ALTERNATIVELY we prove this by a *series expansion*,

$$\frac{\sin z}{z^5} = \frac{1}{z^5} \left\{ z - \frac{z^3}{3!} + \frac{z^5}{5!} - \cdots \right\} = \frac{1}{z^4} - \frac{1}{6} \frac{1}{z^2} + \frac{1}{120} - \cdots,$$

from which we derive that

$$\operatorname{res}\left(\frac{\sin z}{z^5}; 0\right) = a_{-1} = 0.$$

ALTERNATIVELY we apply RULE I, because 0 is a pole of *at most* order 5 (the order is in fact 4):

$$\operatorname{res}\left(\frac{\sin z}{z^5}; 0\right) = \frac{1}{4!} \lim_{z \rightarrow 0} \frac{d^4}{dz^4} \sin z = \frac{1}{4!} \lim_{z \rightarrow 0} \sin z = 0.$$

(b) We have in a neighbourhood of 0 (exclusive 0 itself),

$$\frac{\operatorname{Log}(1+z)}{z^2} = \frac{1}{z^2} \left\{ z - \frac{z^2}{2} + \frac{z^3}{3} - \cdots \right\} = \frac{1}{z} - \frac{1}{2} + \frac{z}{3} - \cdots,$$

so

$$\operatorname{res}\left(\frac{\operatorname{Log}(1+z)}{z^2}; 0\right) = a_{-1} = 1.$$

ALTERNATIVELY, $z = 0$ is a pole of *at most* order 2 (its order is 1), so by RULE I,

$$\operatorname{res}\left(\frac{\operatorname{Log}(1+z)}{z^2}; 0\right) = \frac{1}{1!} \lim_{z \rightarrow 0} \frac{d}{dz} \operatorname{Log}(1+z) = \lim_{z \rightarrow 0} \frac{1}{1+z} = 1.$$

Example 2.7 Find the residues of all singularities in \mathbb{C} of

$$(a) \frac{1}{z(z-1)}, \quad (b) \frac{z}{z^4+1}, \quad (c) \frac{\sin z}{z^2(\pi-z)}.$$

(a) The function

$$f(z) = \frac{1}{z(z-1)}$$

has the simple poles 0 and 1. Then by RULE I:

$$\operatorname{res}(f; 0) = \lim_{z \rightarrow 0} z \cdot f(z) = \lim_{z \rightarrow 0} \frac{1}{z-1} = -1,$$

$$\operatorname{res}(f; 1) = \lim_{z \rightarrow 1} (z-1)f(z) = \lim_{z \rightarrow 1} \frac{1}{z} = 1.$$

(b) Here we have the four *simple* poles

$$\exp\left(i\frac{\pi}{4}\right), \quad \exp\left(i\frac{3\pi}{4}\right), \quad \exp\left(i\frac{5\pi}{4}\right), \quad \exp\left(i\frac{7\pi}{4}\right).$$

If we put

$$A(z) = z \quad \text{and} \quad B(z) = z^4 + 1,$$

and let z_0 denote any of these simple poles, then $z_0^4 = -1$ for all four of them, and we conclude by RULE II that

$$\operatorname{res}(f; z_0) = \frac{A(z_0)}{B'(z_0)} = \frac{z_0}{4z_0^3} = \frac{1}{4} \cdot \frac{1}{z_0^4} \cdot z_0^2 = -\frac{z_0^2}{4},$$

hence

$$\operatorname{res}\left(f; \exp\left(i\frac{\pi}{4}\right)\right) = -\frac{1}{4} \exp\left(i\frac{\pi}{2}\right) = -\frac{i}{4};$$

$$\operatorname{res}\left(f; \exp\left(i\frac{3\pi}{4}\right)\right) = -\frac{1}{4} \exp\left(i\frac{3\pi}{2}\right) = \frac{i}{4};$$

$$\operatorname{res}\left(f; \exp\left(i\frac{5\pi}{4}\right)\right) = -\frac{1}{4} \exp\left(i\frac{5\pi}{2}\right) = -\frac{i}{4};$$

$$\operatorname{res}\left(f; \exp\left(i\frac{7\pi}{4}\right)\right) = -\frac{1}{4} \exp\left(i\frac{7\pi}{4}\right) = \frac{i}{4}.$$

(c) Clearly, the singularity at $z = \pi$ is *removable*, so

$$\operatorname{res}(f; \pi) = 0.$$

Since

$$\frac{\sin z}{z} \rightarrow 1 \quad \text{for } z \rightarrow 0,$$

the singularity at $z = 0$ is a *simple* pole, so

$$\operatorname{res}(f; 0) = \lim_{z \rightarrow 0} z \cdot f(z) = \lim_{z \rightarrow 0} \frac{\sin z}{z} \cdot \frac{1}{\pi - z} = \frac{1}{\pi}.$$

ALTERNATIVELY we consider $z = 0$ as a pole of *at most* order 2, so it follows by RULE I that

$$\operatorname{res}(f; 0) = \frac{1}{1!} \lim_{z \rightarrow 0} \frac{d}{dz} \left(\frac{\sin z}{\pi - z} \right) = \lim_{z \rightarrow 0} \left\{ \frac{\cos z}{\pi - z} + \frac{\sin z}{(\pi - z)^2} \right\} = \frac{1}{\pi}.$$

Analogously we can consider $z = \pi$ as a “pole” of *at most* order 1. Then by RULE I,

$$\operatorname{res}(f; \pi) = \lim_{z \rightarrow \pi} \left\{ -\frac{\sin z}{z^2} \right\} = 0.$$

Example 2.8 Find the residues of all singularities in \mathbb{C} of

$$(a) \frac{z e^{iz}}{(z - \pi)^2}, \quad (b) \frac{z^3 + 5}{(z^4 - 1)(z + 1)}, \quad (c) \frac{e^z}{z^3 - z}.$$

(a) The only singularity is a double pole at $z = \pi$, so it follows from RULE I that

$$\operatorname{res} \left(\frac{z e^{iz}}{(z - \pi)^2}; \pi \right) = \frac{1}{1!} \lim_{z \rightarrow \pi} \frac{d}{dz} (z e^{iz}) = \lim_{z \rightarrow \pi} (e^{iz} + i z e^{iz}) = -1 - i\pi.$$

(b) The function

$$f(z) = \frac{z^3 + 5}{(z^4 - 1)(z + 1)}$$

has the three simple poles 1 , i and $-i$, and the double pole -1 . If we put

$$A(z) = \frac{z^3 + 5}{z + 1} \quad \text{and} \quad B(z) = z^4 - 1,$$

Please click the advert

CHALLENGE YOURSELF

WWW.STUDYINSWEDEN.SE

Si.
Swedish Institute

Today's job market values ambitious, innovative, perceptive team players. Swedish universities foster these qualities through a forward-thinking culture where you're close to the latest ideas and global trends.

Whatever your career goals may be, studying in Sweden will give you valuable skills and a competitive advantage for your future. www.studyinsweden.se

where the simple poles $z_0 = 1, i, -i$, all satisfy $z_0^4 = 1$, then

$$\operatorname{res}(f; z_0) = \frac{A(z_0)}{B'(z_0)} = \frac{1}{4} \cdot \frac{z_0}{z_0^4} \cdot \frac{z_0^3 + 5}{z_0 + 1} = \frac{1}{4} \cdot \frac{1 + 5z_0}{1 + z_0} = \frac{1}{4} + \frac{z_0}{1 + z_0},$$

hence

$$\operatorname{res}(f; 1) = \frac{1}{4} + \frac{1}{2} = \frac{3}{4};$$

$$\operatorname{res}(f; i) = \frac{1}{4} + \frac{i}{1+i} = \frac{3+2i}{4};$$

$$\operatorname{res}(f; -i) = \frac{1}{4} - \frac{i}{1-i} = \frac{3-2i}{4}.$$

Finally, it follows for the double pole -1 by RULE I,

$$\begin{aligned} \operatorname{res}(f; -1) &= \lim_{z \rightarrow -1} \frac{d}{dz} \left\{ \frac{z^3 + 5}{(z^2 + 1)(z - 1)} \right\} \\ &= \lim_{z \rightarrow -1} \left\{ \frac{3z^2}{(z^2 + 1)(z - 1)} - \frac{2z(z^3 + 5)}{(z^2 + 1)^2(z - 1)} - \frac{z^3 + 5}{(z^2 + 1)(z - 1)^2} \right\} \\ &= \frac{3}{2 \cdot (-2)} - \frac{2(-1) \cdot 4}{2^2 \cdot (-2)} - \frac{4}{2 \cdot (-2)^2} = -\frac{3}{4} - 1 - \frac{1}{2} = -\frac{9}{4}. \end{aligned}$$

CHECK. The sum of the residues is

$$\frac{3}{4} + \frac{3+2i}{4} + \frac{3-2i}{4} - \frac{9}{4} = 0.$$

This agrees with the fact that the function has a zero of second order at ∞ , so the residuum in ∞ (the additional term) is 0 in this case.

(c) The poles $z = -1, 0, 1$ are all simple. Therefore we get by RULE I,

$$\begin{aligned} \operatorname{res}(f; -1) &= \lim_{z \rightarrow -1} (z + 1)f(z) = \lim_{z \rightarrow -1} \frac{e^z}{z(z - 1)} = \frac{e^{-1}}{(-1)(-2)} = \frac{1}{2e}, \\ \operatorname{res}(f; 0) &= \lim_{z \rightarrow 0} z f(z) = \lim_{z \rightarrow 0} \frac{e^z}{z^2 - 1} = -1, \\ \operatorname{res}(f; 1) &= \lim_{z \rightarrow 1} (z - 1)f(z) = \lim_{z \rightarrow 1} \frac{e^z}{z(z + 1)} = \frac{e}{2}. \end{aligned}$$

Example 2.9 Find the residues at $z = 0$ of the following functions:

$$(a) \frac{2z + 1}{z(z^3 - 5)}, \quad (b) \frac{e^z}{\sin z}.$$

We have in both cases a simple pole at $z = 0$. As usual there are several possibilities of solutions, of which we only choose one.

(a) It follows by RULE I,

$$\operatorname{res} \left(\frac{2z + 1}{z(z^3 - 5)}; 0 \right) = \lim_{z \rightarrow 0} \frac{2z + 1}{z^3 - 5} = -\frac{1}{5}.$$

(b) In this case RULE II is the easiest one:

$$\operatorname{res} \left(\frac{e^z}{\sin z}; 0 \right) = \lim_{z \rightarrow 0} \frac{e^z}{\cos z} = 1.$$

Example 2.10 Find the residuum at $z = 1$ of

$$\frac{1}{z^n - 1}, \quad n \in \mathbb{N}.$$

Here $z = 1$ is a simple pole, so by RULE II,

$$\operatorname{res} \left(\frac{1}{z^n - 1}; 1 \right) = \lim_{z \rightarrow 1} \frac{1}{n z^{n-1}} = \frac{1}{n}.$$

ADDITION. Let z_0 denote any one of the simple poles, i.e. $z_0^n = 1$. Then it follows by RULE II that

$$\operatorname{res} \left(\frac{1}{z^n - 1}; z_0 \right) = \frac{1}{n z_0^{n-1}} \cdot \frac{z_0}{z_0} = \frac{z_0}{n}. \quad \diamond$$

Example 2.11 Find the residues at all singularities in \mathbb{C} of

$$(a) \frac{1}{(z^2 - 1)(z + 2)}, \quad (b) \frac{(z^3 - 1)(z + 2)}{(z^4 - 1)^2}, \quad (c) \exp \left(\frac{1}{z - 1} \right).$$

(a) The poles at -2 , -1 and 1 are all simple, hence by RULE I,

$$\operatorname{res} \left(\frac{1}{(z^2 - 1)(z + 2)}; -2 \right) = \lim_{z \rightarrow -2} \frac{1}{z^2 - 1} = \frac{1}{3},$$

$$\operatorname{res} \left(\frac{1}{(z^2 - 1)(z + 2)}; -1 \right) = \lim_{z \rightarrow -1} \frac{1}{(z - 1)(z + 2)} = -\frac{1}{2},$$

$$\operatorname{res} \left(\frac{1}{(z^2 - 1)(z + 2)}; 1 \right) = \lim_{z \rightarrow 1} \frac{1}{(z + 1)(z + 2)} = \frac{1}{6}.$$

Remark 2.1 Here,

$$\operatorname{res}\left(\frac{1}{(z^2-1)(z+2)}; -2\right) + \operatorname{res}\left(\frac{1}{(z^2-1)(z+2)}; -1\right) + \operatorname{res}\left(\frac{1}{(z^2-1)(z+2)}; 1\right) = 0,$$

in agreement with the fact that we have a zero of order 3 at ∞ , so the residuum here (the additional term) is 0. \diamond

(b) The poles are her $z = 1, i, -1, -i$, and $z = 1$ is a simple pole, while the other ones are double poles. Hence by various applications of RULE I,

$$\operatorname{res}(f; 1) = \lim_{z \rightarrow 1} (z-1) \frac{(z^3-1)(z+2)}{(z^4-1)^2} = \lim_{z \rightarrow 1} \frac{\frac{z^3-1}{z-1} \cdot (z+2)}{\left(\frac{z^4-1}{z-1}\right)^2} = \lim_{z \rightarrow 1} \frac{3z^2(z+2)}{(4z^3)^2} = \frac{9}{16},$$

$$\begin{aligned} \operatorname{res}(f; -1) &= \lim_{z \rightarrow -1} \frac{d}{dz} \left\{ \frac{(z^3-1)(z+2)}{(z^2+1)^2(z-1)^2} \right\} \\ &= \lim_{z \rightarrow -1} \left\{ \frac{3z^2(z+2)+z^3-1}{(z^2+1)^2(z-1)^2} - \frac{2 \cdot 2z(z^3-1)(z+2)}{(z^2+1)^3(z-1)^2} - \frac{2(z^3-1)(z+2)}{(z^2+1)^2(z-1)^3} \right\} \\ &= \frac{3 \cdot 1 - 1 - 1}{2^2 \cdot (-2)^2} - \frac{2 \cdot 2 \cdot (-1) \cdot (-2) \cdot 1}{2^3 \cdot (-2)^2} - \frac{2 \cdot (-2) \cdot 1}{2^2 \cdot (-2)^3} = \frac{1}{16} - \frac{4}{16} - \frac{2}{16} = -\frac{5}{16}, \end{aligned}$$

$$\begin{aligned} \operatorname{res}(f; i) &= \lim_{z \rightarrow i} \frac{d}{dz} \left\{ \frac{(z^3-1)(z+2)}{(z+i)^2(z^2-1)^2} \right\} \\ &= \lim_{z \rightarrow i} \left\{ \frac{3z^2(z+2)+z^3-1}{(z+i)^2(z^2-1)^2} - \frac{2(z^3-1)(z+2)}{(z+i)^2(z^2-1)^2} - \frac{2 \cdot 2z(z^3-1)(z+2)}{(z+i)^2(z^2-1)^3} \right\} \\ &= \frac{-3(2+i) - i - 1}{-4 \cdot (-2)^2} - \frac{2 \cdot (-1-i)(2+i)}{-8i(-2)^2} - \frac{4i(-1-i)(2+i)}{-4(-2)^3} \\ &= \frac{7+4i}{16} + \frac{-1-3i}{16i} - \frac{2i(-1-3i)}{16} = \frac{7+4i}{16} + \frac{-3+i}{16} + \frac{-6+2i}{16} = \frac{-2+7i}{16}, \end{aligned}$$

$$\begin{aligned} \operatorname{res}(f; -i) &= \lim_{z \rightarrow -i} \frac{d}{dz} \left\{ \frac{(z^3-1)(z+2)}{(z-i)^2(z^2-1)^2} \right\} \\ &= \lim_{z \rightarrow -i} \left\{ \frac{3z^2(z+2)+z^3-1}{(z-i)^2(z^2-1)^2} - \frac{2(z^3-1)(z+2)}{(z-i)^3(z^2-1)^2} - \frac{2 \cdot 2z(z^3-1)(z+2)}{(z-i)^2(z^2-1)^3} \right\} \\ &= \frac{-3(2-i) + i - 1}{-4 \cdot (-2)^2} - \frac{2(-1+i)(2-i)}{8i(-2)^2} - \frac{(-4i)(-1+i)(2-i)}{-4 \cdot (-2)^3} = \overline{\operatorname{res}(f; i)} = \frac{-2-7i}{16}. \end{aligned}$$

Note again that the sum of residues is 0.

- (c) The only singularity here is $z = 1$. It is essential, so we must expand into a Laurent series from $z_0 = 1$,

$$\exp\left(\frac{1}{z-1}\right) = 1 + \frac{1}{z-1} + \dots, \quad , z \neq 1.$$

It follows that

$$\operatorname{res}\left(\exp\left(\frac{1}{z-1}\right); 1\right) = a_{-1} = 1.$$

Please click the advert

Turning a challenge into a learning curve. Just another day at the office for a high performer.

Accenture Boot Camp – your toughest test yet

Choose Accenture for a career where the variety of opportunities and challenges allows you to make a difference every day. A place where you can develop your potential and grow professionally, working alongside talented colleagues. The only place where you can learn from our unrivalled experience, while helping our global clients achieve high performance. If this is your idea of a typical working day, then Accenture is the place to be.

It all starts at Boot Camp. It's 48 hours that will stimulate your mind and enhance your career prospects. You'll spend time with other students, top Accenture Consultants and special guests. An inspirational two days

packed with intellectual challenges and activities designed to let you discover what it really means to be a high performer in business. We can't tell you everything about Boot Camp, but expect a fast-paced, exhilarating

and intense learning experience. It could be your toughest test yet, which is exactly what will make it your biggest opportunity.

Find out more and apply online.

Visit [accenture.com/bootcamp](https://www.accenture.com/bootcamp)

• Consulting • Technology • Outsourcing

High performance. Delivered.

Example 2.12 Prove that the functions

$$(a) \frac{1}{\sin z}, \quad (b) \frac{1}{1 - e^z},$$

only have simple poles in \mathbb{C} . Find these and their corresponding residues.

(a) The poles of $\frac{1}{\sin z}$ are the same as the zeros of $\sin z$ and of the same multiplicity. The function $\sin z$ has the zeros $\{p\pi \mid p \in \mathbb{Z}\}$, where

$$\lim_{z \rightarrow p\pi} \frac{d}{dz} \sin z = \lim_{z \rightarrow p\pi} \cos z = (-1)^p \neq 0,$$

hence all poles are simple. Finally, it follows by RULE II that

$$\operatorname{res} \left(\frac{1}{\sin z}; p\pi \right) = \lim_{z \rightarrow p\pi} \frac{1}{\cos z} = (-1)^p, \quad p \in \mathbb{Z}.$$

(b) The poles of $\frac{1}{1 - e^z}$ are the same as the zeros of $1 - e^z$ and of the same multiplicity. The zeros are $z = 2ip\pi$, $p \in \mathbb{Z}$, and since

$$\frac{d}{dz} (1 - e^z) = -e^z \neq 0 \quad \text{for every } z \in \mathbb{C},$$

all poles are simple. Hence by RULE II,

$$\operatorname{res} \left(\frac{1}{1 - e^z}; 2ip\pi \right) = \lim_{z \rightarrow 2ip\pi} \frac{1}{-e^z} = -1, \quad p \in \mathbb{Z}.$$

Example 2.13 Find the residues at all singularities in \mathbb{C} of

$$\frac{1}{1 - \cos z}.$$

The function $\frac{1}{1 - \cos z}$ has a (non-isolated) essential singularity at ∞ , and otherwise only poles in \mathbb{C} . The poles are determined by the equation $1 - \cos z = 0$, thus

$$(1) \quad 0 = 1 - \cos z = 2 \sin^2 \frac{z}{2},$$

the complete solution of which is $z = 2p\pi$, $p \in \mathbb{Z}$. It follows from (1) that the zeros are all of second order, hence the poles $z = 2p\pi$, $p \in \mathbb{Z}$, of $\frac{1}{1 - \cos z}$ are all of second order. We then have by RULE I

and L'HOSPITAL'S RULE the following dreadful computation,

$$\begin{aligned}
\operatorname{res}\left(\frac{1}{1-\cos z}; 2p\pi\right) &= \frac{1}{1!} \lim_{z \rightarrow 2p\pi} \frac{d}{dz} \left\{ \frac{(z-2p\pi)^2}{1-\cos z} \right\} \\
&= \lim_{z \rightarrow 2p\pi} \frac{2(z-2p\pi)(1-\cos z) - (z-2p\pi)^2 \sin z}{(1-\cos z)^2} \\
&= \lim_{z \rightarrow 2p\pi} \frac{2(z-2p\pi) \cdot 2 \sin^2 \frac{z}{2} - (z-2p\pi)^2 \cdot 2 \sin \frac{z}{2} \cos \frac{z}{2}}{(2 \sin^2 \frac{z}{2})^2} \\
&= \frac{1}{2} \lim_{z \rightarrow 2p\pi} \frac{2(2 \cdot \frac{z}{2} - 2p\pi) \sin \frac{z}{2} - (2 \cdot \frac{z}{2} - 2p\pi)^2 \cos \frac{z}{2}}{\sin^3 \frac{z}{2}} \\
&= 2 \lim_{w \rightarrow p\pi} \frac{(w-p\pi) \sin w - (w-p\pi)^2 \cos w}{\sin^3 w} \\
&= 2 \lim_{w \rightarrow p\pi} \frac{\sin w + (w-p\pi) \cos w - 2(w-p\pi) \cos w - (w-p\pi)^2 \sin w}{3 \sin^2 w \cdot \cos w} \\
&= \frac{2}{3} \lim_{w \rightarrow p\pi} \frac{\sin w - (w-p\pi) \cos w + (w-p\pi)^2 \sin w}{\sin^2 w \cdot \cos w} \\
&= \frac{2}{3} \lim_{w \rightarrow p\pi} \frac{\cos w - \cos w + (w-p\pi) \sin w + 2(w-p\pi) \sin w + (w-p\pi)^2 \cos w}{2 \sin w \cdot \cos^2 w - \sin^3 w} \\
&= \frac{2}{3} \lim_{w \rightarrow p\pi} \frac{3(w-p\pi) \sin w + (w-p\pi)^2 \cos w}{2 \sin w \cdot \cos^2 w - \sin^3 w} \\
&= \frac{2}{3} \lim_{w \rightarrow p\pi} \frac{3 \sin w + 3(w-p\pi) \cos w + 2(w-p\pi) \cos w - (w-p\pi)^2 \sin w}{2 \cos^3 w - 4 \sin^2 w \cdot \cos w - 3 \sin^2 w \cdot \cos w} \\
&= 0.
\end{aligned}$$

Remark 2.2 Whenever one apparently has to go through some heavy computations like the previous ones, one should check if there should not be another easier method. Here it would have been cheating the reader first to bring the simple solution, so for pedagogical reasons we have first given the standard solution.

An ALTERNATIVE method of solution is the following: First note that we have for every $z \in \mathbb{C}$ and every $p \in \mathbb{Z}$ that

$$\cos((z+2p\pi) - 2p\pi) = \cos(-(z+2p\pi) - 2p\pi),$$

which is just another way of saying that the function $1 - \cos z$ is an *even* function with respect to any $2p\pi$, $p \in \mathbb{Z}$, so if we expand the function from some $2p\pi$, then it is again *even*. In a Laurent series expansion of any *even* function all coefficients a_{2n+1} , $n \in \mathbb{Z}$, of odd indices must be equal to 0. In particular,

$$\operatorname{res}\left(\frac{1}{1-\cos z}; 2p\pi\right) = a_{-1} = 0 \quad \text{for every } p \in \mathbb{Z}. \quad \diamond$$

Example 2.14 Find the residues at all singularities in \mathbb{C} of $\frac{\sinh z}{\sin^2 z}$.

Clearly, the poles are $z = p\pi$, $p \in \mathbb{Z}$, and $z = 0$ is a simple pole. Any other pole $z = p\pi$, $p \in \mathbb{Z} \setminus \{0\}$ is a double pole.

When we apply RULE I, we get

$$\operatorname{res}(f; 0) = \lim_{z \rightarrow 0} \frac{z \cdot \sinh z}{\sin^2 z} = \lim_{z \rightarrow 0} \frac{z \left(z + \frac{z^3}{3!} + \dots \right)}{\left(z - \frac{z^3}{3!} + \dots \right)^2} = \lim_{z \rightarrow 0} \frac{z^2 \left(1 + \frac{z^2}{6} + \dots \right)}{z^2 \left(1 - \frac{z^2}{6} + \dots \right)^2} = 1,$$

and

$$\operatorname{res} \left(\frac{\sinh z}{\sin^2 z}; p\pi \right) = \frac{1}{1!} \lim_{z \rightarrow p\pi} \frac{d}{dz} \left\{ \frac{(z - p\pi)^2 \sinh z}{\sin^2 z} \right\} = \lim_{z \rightarrow 0} \frac{d}{dz} \left\{ \frac{z^2 \sinh(z + p\pi)}{\sin^2 z} \right\} = a_1,$$

where we to ease matters have put

$$(2) \quad \frac{z^2 \sinh(z + p\pi)}{\sin^2 z} = a_0 + a_1 z + \dots, |z| < \pi,$$

because $z = 0$ is a removable singularity, and the function has a Taylor expansion in the open disc of centrum 0 and radius π .

The task is now to determine the coefficient a_1 in the Taylor expansion. It is obvious that the usual definition with a differentiation followed by taking a limit becomes very messy. Instead we multiply by the denominator, so (2) becomes equivalent to

$$z^2 \sinh(z + p\pi) = (a_0 + a_1 z + \dots) \sin^2 z = (a_0 + a_1 z + \dots) \cdot \frac{1}{2} (1 - \cos 2z),$$

hence after insertion of the series expansions,

$$\begin{aligned} z^2 \{ \sinh p\pi + \cosh p\pi \cdot z + \dots \} &= (a_0 + a_1 z + \dots) \cdot \frac{1}{2} \left\{ 1 - 1 + \frac{1}{2} (2z)^2 - \frac{1}{4!} (2z)^4 + \dots \right\} \\ &= (a_0 + a_1 z + \dots) \left(z^2 - \frac{1}{3} z^4 + \dots \right), \end{aligned}$$

which for $z \neq 0$ is reduced to

$$\sinh p\pi + \cosh p\pi \cdot z + \dots = (a_0 + a_1 z + \dots) \left(1 - \frac{1}{3} + \dots \right) = a_0 + a_1 z + \dots.$$

When we identify the coefficients, we get

$$a_0 = \sinh p\pi \quad \text{and} \quad a_1 = \cosh p\pi,$$

so we conclude that

$$\operatorname{res} \left(\frac{\sinh z}{\sin^2 z}; p\pi \right) = a_1 = \cosh p\pi, \quad p \in \mathbb{Z} \setminus \{0\},$$

$$\operatorname{res} \left(\frac{\sinh z}{\sin^2 z}; 0 \right) = 1 = \cosh(0 \cdot \pi), \quad p = 0,$$

(cf. the above). Summing up we have in general,

$$\operatorname{res} \left(\frac{\sinh z}{\sin^2 z}; p\pi \right) = \cosh p\pi, \quad p \in \mathbb{Z}.$$

Example 2.15 Find all Laurent series solutions in a disc with the centrum $z_0 = 0$ excluded of the differential equation

$$(z^4 + z^2) f'(z) + 2(z^3 + z) f(z) = 1,$$

and find the value of the complex line integral

$$\oint_{|z|=\frac{1}{2}} f(z) dz$$

for everyone of these solutions.

First method. *Inspection.* Let us first try some manipulation,

$$(z^2 + 1) \{z^2 f'(z) + 2z f(z)\} = (z^2 + 1) \frac{d}{dz} \{z^2 f(z)\} = 1.$$

Please click the advert





it's an **interesting** world

Get under the skin of it.

Graduate opportunities
Cheltenham | £24,945 + benefits

One of the UK's intelligence services, GCHQ's role is two-fold: to gather and analyse intelligence which helps shape Britain's response to global events, and, to provide technical advice for the protection of Government communication and information systems. In doing so, our specialists – in IT, internet, engineering, languages, information assurance, mathematics and intelligence – get well beneath the surface of global affairs. If you thought the world was an interesting place, you really ought to explore our world of work.

www.careersinbritishintelligence.co.uk

Applicants must be British citizens. GCHQ values diversity and welcomes applicants from all sections of the community. We want our workforce to reflect the diversity of our work.







When $|z| < 1$ this equation can be written

$$\frac{d}{dz} \{z^2 f(z)\} = \frac{1}{1+z^2} = \sum_{n=0}^{+\infty} (-1)^n z^{2n},$$

hence by termwise integration in the open unit disc $|z| < 1$:

$$z^2 f(z) = C + \sum_{n=0}^{+\infty} \frac{(-1)^n}{2n+1} z^{2n+1} = C + \operatorname{Arctan} z, \quad C \in \mathbb{C} \text{ arbitrary constant,}$$

and the *complete* solution in the disc (without its centrum) is given by

$$f(z) = \frac{C}{z^2} + \sum_{n=0}^{+\infty} \frac{(-1)^n}{2n+1} z^{2n-1} = \frac{C}{z^2} + \frac{\operatorname{Arctan} z}{z^2}, \quad C \in \mathbb{C}, \quad 0 < |z| < 1.$$

The circle $|z| = \frac{1}{2}$ lies in this set, so we conclude that

$$\oint_{|z|=\frac{1}{2}} f(z) dz = 2\pi i \cdot \operatorname{res}(f; 0) = 2\pi i a_{-1} = 2\pi i,$$

which holds for all of the solutions above.

Second method. *The method of series.* The coefficient $z^4 + z^2 = z^2(z^2 + 1)$ is 0 for $z = 0$ or for $z = \pm i$, and the solution $f(z)$ is analytic in its domain. Therefore, we get by inserting the Laurent series

$$f(z) = \sum a_n z^n, \quad f'(z) = \sum n a_n z^{n-1},$$

into the differential equation that

$$\begin{aligned} & (z^4 + z^2) f'(z) + 2(z^3 + z) f(z) \\ &= \sum n a_n z^{n+3} + \sum n a_n z^{n+1} + \sum 2a_n z^{n+3} + \sum 2a_n z^{n+1} \\ &= \sum (n+2) a_n z^{n+3} + \sum (n+2) a_n z^{n+1} \\ &= \sum n a_{n-2} z^{n+1} + \sum (n+2) a_n z^{n+1} \\ &= \sum \{n a_{n-2} + (n+2) a_n\} z^{n+1}. \end{aligned}$$

This expression is the *identity theorem* equal to 1, if $-a_{-3} + a_{-1} = 1$ and the following *recursion formula* holds,

$$n a_{n-2} + (n+2) a_n = 0, \quad \text{for } n \in \mathbb{Z} \setminus \{-1\}.$$

If $n = 0$, then $a_0 = 0$ and a_{-2} is an indeterminate. Then it follows by recursion that $a_{2n} = 0$ for $n \in \mathbb{N}_0$.

If $n = -2$, then $a_{-4} = 0$ and a_{-2} is an indeterminate. It follows by recursion that $a_{-2n} = 0$ for $n \in \mathbb{N} \setminus \{1\}$.

It only remains to find the coefficients of odd indices, where we have already proved that

$$-a_{-3} + a_{-1} = 1.$$

We have for the odd indices the recursion formulæ

$$a_{2n-1} = -\frac{2n-1}{2n+3} a_{2n-3}, \quad n \in \mathbb{N},$$

and

$$a_{-2n-3} = -\frac{-2n+1}{-2n-1} a_{-2n-1}, \quad n \in \mathbb{N}.$$

Hence by recursion for the positive, odd indices,

$$a_{2n-1} = -\frac{2n-1}{2n+1} a_{2n-3} = \cdots = (-1)^n \cdot \frac{2n-1}{2n+1} \cdot \frac{2n-3}{2n-1} \cdots \frac{3}{5} \cdot \frac{1}{3} \cdot a_{-1} = \frac{(-1)^n}{2n+1},$$

where the corresponding series is convergent for $0 < |z| < 1$. This series is determined by the coefficient a_{-1} .

The analogous coefficients corresponding to the negative odd indices ≤ 3 have a similar structure, corresponding to the domain of convergence given by $\left|\frac{1}{z}\right| < 1$, i.e. the set given by $|z| > 1$. This series is determined by the coefficient a_{-3} .

Please click the advert

Brain power

By 2020, wind could provide one-tenth of our planet's electricity needs. Already today, SKF's innovative know-how is crucial to running a large proportion of the world's wind turbines.

Up to 25 % of the generating costs relate to maintenance. These can be reduced dramatically thanks to our systems for on-line condition monitoring and automatic lubrication. We help make it more economical to create cleaner, cheaper energy out of thin air.

By sharing our experience, expertise, and creativity, industries can boost performance beyond expectations. Therefore we need the best employees who can meet this challenge!

The Power of Knowledge Engineering

Plug into The Power of Knowledge Engineering.
Visit us at www.skf.com/knowledge

SKF

Download free books at BookBooN.com

Since $a_{-1} - a_{-3} = 1$, and since the curve $|z| = \frac{1}{2}$ lies in the set $0 < |z| < 1$, we must necessarily have $a_{-3} = 0$, and hence $a_{-1} = 1$. Therefore, the complete solution is in the unit disc given by

$$f(z) = \frac{a_{-2}}{z^2} + \sum_{n=0}^{+\infty} \frac{(-1)^n}{2n+1} z^{2n-1}, \quad a_2 \in \mathbb{C}, \quad 0 < |z| < 1.$$

Since the circle $|z| = \frac{1}{2}$ lies in the set $0 < |z| < 1$, we get for each of these solutions that

$$\oint_{|z|=\frac{1}{2}} f(z) dz = 2\pi i a_{-1} = 2\pi i \operatorname{res}(f; 0) = 2\pi i.$$

Example 2.16 Find all Laurent series of the form

$$f(z) = \frac{a_{-1}}{z} + \sum_{n=0}^{+\infty} a_n z^n = \sum_{n=-1}^{+\infty} a_n z^n,$$

which are solutions of the differential equation

$$(z - z^2) \frac{df}{dz} - (z - 1) f(z) = 1 + z,$$

and find the annulus $r < |z| < R$, in which these Laurent series are convergent.

Choose any constant $c \in]r, R[$. Find for any of the solutions above the value of the line integral

$$\oint_{|z|=c} f(z) dz.$$

Express each of the solutions $f(z)$ by means of elementary functions in the domain of convergence.

HINT: Consider e.g. $\frac{1}{2} z f(z)$.

First method. Inspection. The differential equation has the singular points $z = 0$ and $z = 1$, so we may expect that the domain is given by $0 < |z| < 1$. In this set the equation can be divided by $1 - z \neq 0$. Then

$$z \cdot \frac{df}{dz} + 1 \cdot f(z) = \frac{d}{dz} (z \cdot f(z)) = \frac{1+z}{1-z} = -1 + \frac{2}{1-z}.$$

The differential equation can now be written

$$(3) \quad \frac{d}{dz} (z \cdot f(z)) = -1 + \frac{2}{1-z}.$$

If $|z| < 1$, then $1 - z$ lies in the right half plane, so $\operatorname{Log}(1 - z)$ is defined for $|z| < 1$. When we integrate (3), we get

$$z \cdot f(z) = -z - 2\operatorname{Log}(1 - z) + C,$$

thus

$$f(z) = \frac{C}{z} - 1 - 2 \frac{\operatorname{Log}(1-z)}{z}, \quad 0 < |z| < 1, \quad C \in \mathbb{C}.$$

We have now answered the *last question* of the example.

Since

$$\operatorname{Log}(1-z) = - \sum_{n=0}^{+\infty} \frac{1}{n+1} z^{n+1} \quad \text{for } |z| < 1,$$

it follows by insertion that

$$f(z) = \frac{C}{z} - 1 + 2 \sum_{n=0}^{+\infty} \frac{1}{n+1} z^{n+1} = \frac{C}{z} + 1 + \sum_{n=1}^{+\infty} \frac{2}{n+1} z^n \quad \text{for } 0 < |z| < 1.$$

This shows that all Laurent series solutions are given by

$$f(z) = \frac{C}{z} + 1 + \sum_{n=1}^{+\infty} \frac{2}{n+1} z^n, \quad 0 < |z| < 1, \quad C \in \mathbb{C}.$$

Then it is easy to prove that if $c \in]0, 1[$, then

$$\oint_{|z|=c} f(z) dz = \oint_{|z|=c} \frac{a_{-1}}{z} dz = 2\pi i \operatorname{res}(f; 0) = 2\pi i a_{-1} = 2\pi i \cdot C, \quad C \in \mathbb{C}.$$

A VARIANT is to expand $\frac{2}{1-z} - 1$ in a series. Then the equation becomes

$$\frac{d}{dz} (z \cdot f(z)) = -1 + \frac{2}{1-z} = -1 + 2 \sum_{n=0}^{+\infty} z^n = 1 + 2 \sum_{n=1}^{+\infty} z^n, \quad |z| < 1.$$

We get by termwise integration in the disc $|z| < 1$,

$$z \cdot f(z) = C + z + \sum_{n=1}^{+\infty} \frac{2}{n+1} z^{n+1}, \quad |z| < 1, \quad C \in \mathbb{C},$$

hence

$$f(z) = \frac{C}{z} + 1 + \sum_{n=1}^{+\infty} \frac{2}{n+1} z^n, \quad 0 < |z| < 1, \quad C \in \mathbb{C}.$$

Clearly, these Laurent series have their domains of convergence $0 < |z| < 1$, when $C \neq 0$, and $|z| < 1$ if $C = 0$.

Second method. *The method of series.* If we put

$$f(z) = \sum_{n=-1}^{+\infty} a_n z^n \quad \text{og} \quad \frac{df}{dz} = \sum_{n=-1}^{+\infty} n a_n z^{n-1}$$

into the differential equation, then

$$\begin{aligned} 1+z &= (z-z^2) \frac{df}{dz} - (z-1)f(z) \\ &= \sum_{n=-1}^{+\infty} n a_n z^n - \sum_{n=-1}^{+\infty} n a_n z^{n+1} - \sum_{n=-1}^{+\infty} a_n z^{n+1} + \sum_{n=-1}^{+\infty} a_n z^n \\ &= \sum_{n=-1}^{+\infty} (n+1) a_n z^n - \sum_{n=-1}^{+\infty} (n+1) a_n z^{n+1} = \sum_{n=0}^{+\infty} (n+1) a_n z^n - \sum_{n=0}^{+\infty} n a_{n-1} z^n \\ &= 1 \cdot a_0 + 2a_1 z - 0 \cdot a_{-1} - 1 \cdot a_0 z + \sum_{n=2}^{+\infty} \{(n+1)a_n - n a_{n-1}\} z^n \\ &= a_0 + (2a_1 - a_0) z + \sum_{n=2}^{+\infty} \{(n+1)a_n - n a_{n-1}\} z^n. \end{aligned}$$

Then it follows by the *identity theorem* that

$$\begin{cases} a_0 = 1, \\ 2a_1 - a_0 = 1, \\ (n+1)a_n = n a_{n-1} \quad \text{for } n \geq 2. \end{cases}$$

We get $a_0 = 1$ and $a_1 = 1$, and then from the recursion formula,

$$(n+1)a_n = n a_{n-1} = \cdots = 2 \cdot a_1 = 2, \quad n \geq 2,$$

thus

$$a_n = \frac{2}{n+1} \quad \text{for } n \geq 2.$$

Finally, we note that a_{-1} is an indeterminate, so

$$f(z) = \frac{a_{-1}}{z} + 1 + z + \sum_{n=2}^{+\infty} \frac{2}{n+1} z^n, \quad 0 < |z| < 1.$$

Clearly, the power series has the domain of convergence $|z| < 1 = R$.

If $a_{-1} \neq 0$, then $r = 0$, so we get $0 < |z| < 1$.

Clearly, if $c \in]0, 1[$, then

$$\oint_{|z|=c} f(z) dz = \oint_{|z|=c} \frac{a_{-1}}{z} dz = 2\pi i a_{-1}.$$

Finally, we have in the given domain,

$$\begin{aligned} \frac{1}{2}z \cdot f(z) &= \frac{1}{2}a_{-1} + \frac{1}{2}z + \frac{1}{2}z^2 + \sum_{n=2}^{+\infty} \frac{1}{n+1} z^{n+1} \\ &= \sum_{n=0}^{+\infty} \frac{1}{n+1} z^{n+1} - \frac{1}{1}z - \frac{1}{2}z^2 + \frac{1}{2}a_{-1} + \frac{1}{2}z + \frac{1}{2}z^2 \\ &= -\sum_{n=0}^{+\infty} \frac{(-1)^n}{n+1} (-z)^{n+1} + \frac{1}{2}a_{-1} - \frac{1}{2}z = \frac{1}{2}a_{-1} - \frac{1}{2}z - \text{Log}(1-z), \end{aligned}$$

and hence for $0 < |z| < 1$,

$$f(z) = \frac{a_{-1}}{z} - 1 - 2 \cdot \frac{\text{Log}(1-z)}{z}.$$

Trust and responsibility

NNE and Pharmaplan have joined forces to create NNE Pharmaplan, the world's leading engineering and consultancy company focused entirely on the pharma and biotech industries.

Inés Aréizaga Esteva (Spain), 25 years old
Education: Chemical Engineer

– You have to be proactive and open-minded as a newcomer and make it clear to your colleagues what you are able to cope. The pharmaceutical field is new to me. But busy as they are, most of my colleagues find the time to teach me, and they also trust me. Even though it was a bit hard at first, I can feel over time that I am beginning to be taken seriously and that my contribution is appreciated.

Please click the advert



NNE Pharmaplan is the world's leading engineering and consultancy company focused entirely on the pharma and biotech industries. We employ more than 1500 people worldwide and offer global reach and local knowledge along with our all-encompassing list of services.
nnepharmaplan.com

nne pharmaplan®

Example 2.17 *Given*

$$f(z) = \frac{\tanh \pi z}{z(z-i)}, \quad z \in \mathbb{C} \setminus \{z_n \mid n \in \mathbb{Z}\}.$$

- (a) Find the isolated singularities $\{z_n \mid n \in \mathbb{Z}\}$ for $f(z)$, and indicate their type.
 (b) Compute the residuum of $f(z)$ in every pole.
 (c) Prove that we have for every real $c \neq 0$,

$$|\tanh(\pi\{c + it\})| \leq |\coth(\pi c)|, \quad t \in \mathbb{R}.$$

- (d) Assume that $a > 0$, and let C_a denote the boundary of the rectangle of the corners a , $a + i$, $-a + i$ and $-a$. Explain why

$$(4) \oint_{C_a} f(z) dz = \oint_{C_a} \frac{\tanh \pi z}{z(z-i)} dz$$

is defined, and find the value of this line integral.

- (e) Prove that the improper integral

$$\int_{-\infty}^{+\infty} \frac{\tanh \pi x}{z(1+x^2)} dx$$

is convergent, and find – possibly by taking the limit $a \rightarrow +\infty$ in (4) – the value of this integral.

- (a) The singularities are given by $z = 0$, $z = i$ and $\cosh \pi z = 0$, thus $\pi z = i \frac{\pi}{2} + i n \pi$, $n \in \mathbb{Z}$. Hence, the singularities are

$$z'_0 = 0, \quad z'_1 = i \quad \text{and} \quad z_n = i \left(n + \frac{1}{2} \right), \quad n \in \mathbb{Z}.$$

It is almost obvious that $z'_0 = 0$ and $z'_1 = i$ are *removable singularities*, because

$$\lim_{z \rightarrow 0} \frac{\tanh \pi z}{z(z-i)} = -\frac{1}{i} \lim_{z \rightarrow 0} \frac{\tanh \pi z}{z} = i \lim_{z \rightarrow 0} \frac{\frac{\pi}{\cosh^2 \pi z}}{1} = \pi i,$$

and

$$\lim_{z \rightarrow i} \frac{\tanh \pi z}{z(z-i)} = \frac{1}{i} \lim_{z \rightarrow i} \frac{\tanh \pi z}{z-i} = -i \lim_{z \rightarrow i} \frac{\frac{\pi}{\cosh^2 \pi z}}{1} = \frac{-\pi i}{(\cosh i \pi)^2} = -\pi i,$$

where the assumptions of l'Hospital's rule are fulfilled, and

$$(\cosh(i \pi))^2 = (\cos \pi)^2 = (-1)^2 = 1.$$

Furthermore, the singularities

$$z_n = i \left(n + \frac{1}{2} \right), \quad n \in \mathbb{Z},$$

are all *simple poles*. In fact, $\frac{1}{z(z-i)}$ is defined for all z_n , and for

$$\tanh \pi z = \frac{\sinh \pi z}{\cosh \pi z}$$

the denominator $\cosh \pi z$ has a simple zero at each z_n .

(b) According to (a), the poles are given by

$$z_n = i \left(n + \frac{1}{2} \right), \quad n \in \mathbb{Z},$$

and they are all simple. When we apply RULE II, we get

$$\begin{aligned} \operatorname{res} \left(\frac{\tanh \pi z}{z(z-i)}; z_n \right) &= \operatorname{res} \left(\frac{\sinh \pi z}{z(z-i)} \cdot \frac{1}{\cosh \pi z}; i \left(n + \frac{1}{2} \right) \right) = \lim_{z \rightarrow i(n+\frac{1}{2})} \frac{\sinh \pi z}{z(z-i)} \cdot \frac{1}{\pi \cdot \sinh \pi z} \\ &= \frac{1}{\pi} \cdot \frac{1}{i \left(n + \frac{1}{2} \right) i \left(n - \frac{1}{2} \right)} = -\frac{1}{\pi} \cdot \frac{1}{n^2 - \frac{1}{4}} = \frac{4}{\pi} \cdot \frac{1}{1 - 4n^2}, \quad n \in \mathbb{Z}. \end{aligned}$$

(c) Using the definitions of the complex hyperbolic functions we get

$$|\tanh(\pi\{c + it\})|^2 = \frac{|\sin(\pi\{c + it\})|^2}{|\cosh(\pi\{c + it\})|^2} = \frac{\cosh^2(\pi c) - \cos^2(\pi t)}{\sinh^2(\pi c) + \cos^2(\pi t)} \leq \frac{\cosh^2(\pi c)}{\sinh^2(\pi c)} = \coth^2(\pi c),$$

hence the estimate,

$$|\tanh(\pi\{c + it\})| \leq |\coth(\pi c)|.$$

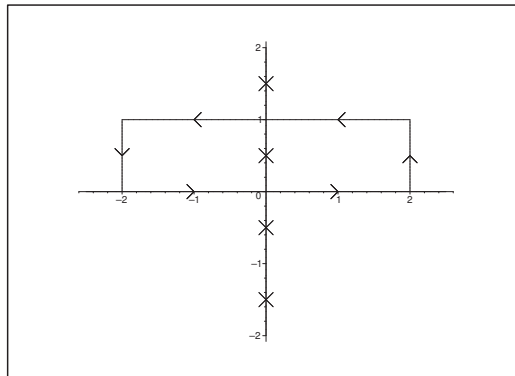

Figure 1: The path of integration C_2 and the poles on the imaginary axis.

(d) The path of integration C_a passes through the two removable singularities $z'_0 = 0$ and $z'_1 = i$. Since $f(z)$ can be continued analytically to these points, the line integral

$$\oint_{C_a} f(z) dz$$

is defined, and we get by *Cauchy's residue theorem* that the value is given by

$$\oint_{C_a} \frac{\tanh \pi z}{z(z-i)} dz = 2\pi i \operatorname{res} \left(f(z); \frac{i}{2} \right) = 2\pi i \operatorname{res} (f(z); z_0) = 2\pi i \cdot \frac{4}{\pi} = 8i,$$

where we have used that z_0 is the only pole inside C_a , and where $\operatorname{res}(f(z); z_n)$ has been computed in (b).

(e) Since

$$\frac{\tanh \pi x}{x} \rightarrow \pi \quad \text{for } x \rightarrow 0,$$

the integrand is continuous on \mathbb{R} . Since

$$\left| \frac{\tanh \pi x}{x(1+x^2)} \right| \leq \frac{1}{1+x^2} \quad \text{for } |x| \geq 1,$$

it follows that $\frac{\tanh \pi x}{x(1+x^2)}$ has an integrable majoring function, so

$$\left| \int_{-\infty}^{+\infty} \frac{\tanh \pi x}{x(1+x^2)} dx \right| \leq \int_{-\infty}^{+\infty} \left| \frac{\tanh \pi x}{x(1+x^2)} \right| dx \leq \int_{-1}^1 \left| \frac{\tanh \pi x}{x(1+x^2)} \right|^2 dx + \int_{-\infty}^{+\infty} \frac{dx}{1+x^2} < +\infty,$$

and the improper integral

$$\int_{-\infty}^{+\infty} \frac{\tanh \pi x}{x(1+x^2)} dx$$

is convergent.

It follows from (d) that

$$\begin{aligned} (5) \quad 8i &= \oint_{C_a} \frac{\tanh \pi z}{z(z-i)} dz \\ &= \int_{-a}^a \frac{\tanh \pi x}{x(x-i)} dx - \int_{-a}^a \frac{\tanh(\pi\{x+i\})}{(x+i)x} dx \\ &\quad + \int_0^1 \frac{\tanh(\pi\{a+it\})}{(a+it)(a+i\{t-1\})} i dt - \int_0^1 \frac{\tanh(\pi\{-a+it\})}{(-a+it)(-a+i\{t-1\})} i dt. \end{aligned}$$

We get by (c) the estimates

$$\left| \int_0^1 \frac{\tanh(\pi\{a+it\})}{(a+it)(a+i\{t-1\})} i dt \right| \leq \frac{|\coth(\pi a)|}{a^2} \cdot 1 \rightarrow 0 \quad \text{for } a \rightarrow +\infty,$$

$$\left| \int_0^1 \frac{\tanh(\pi\{-a+it\})}{(-a+it)(-a+i\{t-1\})} i dt \right| \leq \frac{|\coth(\pi a)|}{a^2} \cdot 1 \rightarrow 0 \quad \text{for } a \rightarrow +\infty.$$

Furthermore,

$$\tanh(\pi\{x+i\}) = \frac{\sinh(\pi x + \pi i)}{\cosh(\pi x + \pi i)} = \frac{\sinh \pi x \cdot \cos \pi + i \cdot \cosh \pi x \cdot \sin \pi}{\cosh \pi x \cdot \cos \pi + i \cdot \sinh \pi x \cdot \sin \pi} = \frac{\sinh \pi x}{\cosh \pi x} = \tanh \pi x,$$

hence by insertion

$$\begin{aligned}\int_{-a}^a \frac{\tanh \pi x}{x(x-i)} dx &= \int_{-a}^a \frac{\tanh(\pi\{x+i\})}{(x+i)x} dx = \int_{-a}^a \frac{\tanh \pi x}{x} \left\{ \frac{1}{x-i} - \frac{1}{x+i} \right\} dx \\ &= \int_{-a}^a \frac{\tanh \pi x}{x} \cdot \frac{2i}{x^2+1} dx = 2i \int_{-a}^a \frac{\tanh \pi x}{x(1+x^2)} dx.\end{aligned}$$

This expression is convergent by the limit $a \rightarrow +\infty$, so it follows from (5) that

$$8i = 2i \int_{-\infty}^{+\infty} \frac{\tanh \pi x}{x(1+x^2)} dx + 0 + 0,$$

and by a rearrangement,

$$\int_{-\infty}^{+\infty} \frac{\tanh \pi x}{x(1+x^2)} dx = 4.$$

Please click the advert

THE MILKWAY
LAUNCHING GRADUATE CAREERS

MILKROUND SYSTEM
Become a business star with internships, placements, graduate jobs & schemes from leading companies.
www.milkround.com

PLANET CAREER ADVICE
Inhabited by insights into business careers and orbited by application advice.

FIRST CONTACT
Get matched to top business employers via intelligent emails landing in your inbox.

Milkround.com: rated the #1 graduate recruitment website in the UK Graduate Careers Survey 2009 of 16,000 university finalists.

Milkround.com

Download free books at BookBooN.com

3 Line integrals computed by means of residues

Example 3.1 An analytic function f in an open annulus

$$\Omega = \{z \in \mathbb{C} \mid 0 < |z| < R\},$$

can be described by its Laurent series:

$$f(z) = \sum_{n=-\infty}^{+\infty} a_n z^n, \quad z \in \Omega.$$

1) Assume that the function is even, i.e.

$$f(z) = f(-z), \quad z \in \Omega.$$

Prove that a_n is zero for all odd values of n .

2) Find the value of the complex line integral

$$\oint_{|z|=1} \frac{1}{z \sin z} dz.$$

1) When f is even, we have in Ω ,

$$0 = f(z) - f(-z) = \sum_{n=-\infty}^{+\infty} \{1 - (-1)^n\} z^n = \sum_{p=-\infty}^{+\infty} 2a_{2p+1} z^{2p+1}.$$

We conclude from the identity theorem that

$$a_{2p+1} = 0 \quad \text{for } p \in \mathbb{Z}.$$

2) If we put $f(z) = \frac{1}{z \sin z}$, then

$$f(-z) = \frac{1}{(-z) \cdot \sin(-z)} = \frac{1}{z \sin z} = f(z),$$

so the integrand is an even function. Then by (1) we have in particular $a_{-1} = 0$, because -1 is an odd index. Then

$$\oint_{|z|=1} \frac{1}{z \sin z} dz = 2\pi i \operatorname{res} \left(\frac{1}{z \sin z}; 0 \right) = 2\pi i a_{-1} = 0.$$

Example 3.2 Find the value of the line integral

$$\oint_{|z|=2} \frac{e^z}{z(z-1)^2} dz.$$

It is not a good idea in this case to use the traditional method of inserting a parametric description and then compute. Note instead that we have inside the curve $|z| = 2$ (seen in its positive direction) the two isolated singularities $z = 0$ and $z = 1$, hence by Cauchy's residue theorem,

$$\int_{|z|=2} \frac{e^z}{z(z-1)^2} dz = 2\pi i \left\{ \operatorname{res} \left(\frac{e^z}{z(z-1)^2}; 0 \right) + \operatorname{res} \left(\frac{e^z}{z(z-1)^2}; 1 \right) \right\}.$$

Now, $z = 0$ is a simple pole, so it follows from Rule Ia that

$$\operatorname{res} \left(\frac{e^z}{z(z-1)^2}; 0 \right) = \lim_{z \rightarrow 0} z f(z) = \lim_{z \rightarrow 0} \frac{e^z}{(z-1)^2} = 1.$$

Since $z = 1$ is a pole of second order, $q = 2$, we get by Rule I,

$$\operatorname{res} \left(\frac{e^z}{z(z-1)^2}; 1 \right) = \frac{1}{(2-1)!} \lim_{z \rightarrow 1} \frac{d^{2-1}}{dz^{2-1}} \{(z-1)^2 f(z)\} = \lim_{z \rightarrow 1} \frac{d}{dz} \left\{ \frac{e^z}{z} \right\} = \lim_{z \rightarrow 1} \frac{e^z}{z^2} (z-1) = 0.$$

Finally, by insertion,

$$\oint_{|z|=2} \frac{e^z}{z(z-1)^2} dz = 2\pi i.$$

Example 3.3 Compute the line integral $\oint_{|z|=2} \frac{z e^z}{z^2 - 1} dz$.

In this case the integrand has two isolated singularities inside $|z| = 2$, namely the two *simple poles* $z = \pm 1$. This gives us a hint of using Rule II. Put $A(z) = z e^z$ and $B(z) = z^2 - 1$. Then $B'(z) = 2z$, and it follows by Rule II that

$$\operatorname{res} \left(\frac{z e^z}{z^2 - 1}; z_0 \right) = \operatorname{res} \left(\frac{A(z)}{B(z)}; z_0 \right) = \frac{A(z_0)}{B'(z_0)} = \frac{z_0 e^{z_0}}{2 z_0} = \frac{1}{2} e^{z_0},$$

where z_0 is anyone of the singularities ± 1 . When we apply Cauchy's residue theorem, we get

$$\oint_{|z|=2} \frac{z e^z}{z^2 - 1} dz = 2\pi i \{ \operatorname{res}(f; 1) + \operatorname{res}(f; -1) \} = 2\pi i \cdot \frac{e^1 + e^{-1}}{2} = 2\pi i \cdot \cosh 1.$$

Example 3.4 Compute the line integral $\oint_{|z|=2} \frac{z}{z^4 - 1} dz$.

The integrand has the four simple poles $1, i, -1$ and $-i$ inside the path of integration. Then by Cauchy's residue theorem,

$$\oint_{|z|=2} \frac{z}{z^4} dz = 2\pi i \{ \operatorname{res}(f; 1) + \operatorname{res}(f; i) + \operatorname{res}(f; -1) + \operatorname{res}(f; -i) \}.$$

When we shall find the residues in several simple poles, "more or less of the same structure", we usually apply Rule II. Let z_0 be anyone of the four simple poles, and put $A(z) = z$ and $B(z) = z^4 - 1$. Then we get by Rule II,

$$\operatorname{res} \left(\frac{z}{z^4 - 1}; z_0 \right) = \frac{A(z_0)}{B'(z_0)} = \frac{z_0}{4z_0^3} = \frac{1}{4} \frac{z_0^2}{z_0^4} = \frac{1}{4} z_0^{-2},$$

hence by insertion,

$$\oint_{|z|=2} \frac{z}{z^4 - 1} dz = \frac{2\pi i}{4} \{1^2 + i^2 + (-1)^2 + (-i)^2\} = 0.$$

Example 3.5 Integrate the function

$$f(z) = \frac{z e^{az}}{1 + e^z}, \quad 0 < a < 1,$$

along the rectangle of the corners $\pm k, \pm k + 2\pi i$, where $k > 0$. Then let k tend towards $+\infty$ in order to find the integrals

$$J_0 = \int_{-\infty}^{+\infty} \frac{e^{ax}}{1 + e^x} dx \quad \text{og} \quad J_1 = \int_{-\infty}^{+\infty} \frac{x e^{ax}}{1 + e^x} dx.$$

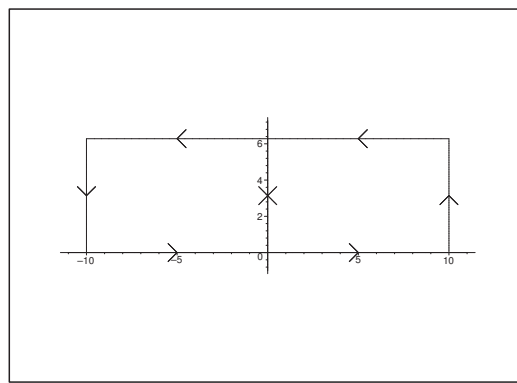

Figure 2: The path of integration C_{10} and the singularity πi .

The integrand $\frac{z e^{az}}{1 + e^z}$ has simple poles for $e^z = -1$, i.e. for

$$z = \pi i + 2ip\pi, \quad p \in \mathbb{Z}.$$

Of these, only $z = \pi i$ lies inside the curve C_k , for all $k > 0$. The function is analytic outside the singularities, so it follows from *Cauchy's residue theorem* for every $k > 0$ that

$$(6) \quad \oint_{C_k} \frac{z e^{az}}{1 + e^z} dz = 2\pi i \operatorname{res} \left(\frac{z e^{az}}{1 + e^z}; \pi i \right) = 2\pi i \cdot \frac{\pi i e^{a\pi i}}{e^{\pi i}} = 2\pi^2 e^{a\pi i},$$

in particular, the value does not depend on $k > 0$.

On the other hand,

$$(7) \quad \oint_{C_k} \frac{z e^{az}}{1 + e^z} dz = \int_{-k}^k \frac{x e^{ax}}{1 + e^x} dx + \int_0^{2\pi} \frac{(k + it)e^{a(k+it)}}{1 + e^{k+it}} i dt - \int_{-k}^k \frac{(x + 2\pi i)e^{a(x+2\pi i)}}{1 + e^{x+2\pi i}} dx - \int_0^{2\pi} \frac{(-k + it)e^{a(-k+it)}}{1 + e^{-k+it}} i dt.$$

Since $0 < a < 1$, it follows by the magnitudes that

$$\int_{-\infty}^{+\infty} \frac{x e^{ax}}{1+e^x} dx \quad \text{and} \quad \int_{-\infty}^{+\infty} \frac{(x+2\pi i)e^{a(x+2\pi i)}}{1+e^{x+2\pi i}} dx$$

exist. We have furthermore the estimates

$$\left| \int_0^{2\pi} \frac{(k+it)e^{a(k+it)}}{1+e^{k+it}} i dt \right| \leq \frac{(k+2\pi)e^{ak}}{e^k-1} \cdot 2\pi \rightarrow 0 \quad \text{for } k \rightarrow +\infty,$$

and

$$\left| \int_0^{2\pi} \frac{(-k+it)e^{a(-k+it)}}{1+e^{-k+it}} i dt \right| \leq \frac{(k+2\pi)e^{ak}}{e^k-1} \cdot 2\pi \rightarrow 0 \quad \text{for } k \rightarrow +\infty.$$

Hence by taking the limit $k \rightarrow +\infty$, we conclude from (6) and (7) that

$$\begin{aligned} 2\pi^2 e^{a\pi i} &= \lim_{k \rightarrow +\infty} \oint_{C_k} \frac{z e^{az}}{1+e^z} dz = \int_{-\infty}^{+\infty} \frac{x e^{ax}}{1+e^x} dx - \int_{-\infty}^{+\infty} \frac{(x+2\pi i)e^{a(x+2\pi i)}}{1+e^{x+2\pi i}} dx \\ &= \int_{-\infty}^{+\infty} \frac{x e^{ax}}{1+e^x} dx - e^{2\pi ai} \int_{-\infty}^{+\infty} \frac{x e^{ax}}{1+e^x} dx - e^{2\pi ai} \cdot 2\pi i \int_{-\infty}^{+\infty} \frac{e^{ax}}{1+e^x} dx \\ &= (1 - e^{2\pi ai}) \int_{-\infty}^{+\infty} \frac{x e^{ax}}{1+e^x} dx - 2\pi i \cdot e^{2\pi ai} \int_{-\infty}^{+\infty} \frac{e^{ax}}{1+e^x} dx, \end{aligned}$$

Please click the advert

CHALLENGE YOURSELF

WWW.STUDYINSWEDEN.SE

Today's job market values ambitious, innovative, perceptive team players. Swedish universities foster these qualities through a forward-thinking culture where you're close to the latest ideas and global trends.

Si.
Swedish Institute

Whatever your career goals may be, studying in Sweden will give you valuable skills and a competitive advantage for your future. www.studyinsweden.se

so by a division by $e^{a\pi i}$,

$$\begin{aligned} 2\pi^2 &= -(e^{\pi a i} - e^{-\pi a i}) \int_{-\infty}^{+\infty} \frac{x e^{ax}}{1+e^x} dx - 2\pi i \cdot e^{\pi a i} \int_{-\infty}^{+\infty} \frac{e^{ax}}{1+e^x} dx \\ &= -2i \sin a\pi \int_{-\infty}^{+\infty} \frac{x e^{ax}}{1+e^x} dx - 2\pi i (\cos \pi a + i \sin \pi a) \int_{-\infty}^{+\infty} \frac{e^{ax}}{1+e^x} dx \\ &= 2\pi \cdot \sin a\pi \int_{-\infty}^{+\infty} \frac{e^{ax}}{1+e^x} dx - 2i \left\{ \sin a\pi \int_{-\infty}^{+\infty} \frac{x e^{ax}}{1+e^x} dx + \pi \cos a\pi \int_{-\infty}^{+\infty} \frac{e^{ax}}{1+e^x} dx \right\}. \end{aligned}$$

Then we get by separating the real and the imaginary parts,

$$2\pi^2 = 2\pi \cdot \sin a\pi \int_{-\infty}^{+\infty} \frac{e^{ax}}{1+e^x} dx,$$

and

$$\sin a\pi \int_{-\infty}^{+\infty} \frac{x e^{ax}}{1+e^x} dx + \pi \cdot \cos a\pi \int_{-\infty}^{+\infty} \frac{e^{ax}}{1+e^x} dx = 0.$$

Finally, we derive that

$$J_0 = \int_{-\infty}^{+\infty} \frac{e^{ax}}{1+e^x} dx = \frac{2\pi^2}{2\pi \cdot \sin a\pi} = \frac{\pi}{\sin a\pi},$$

and

$$J_1 = \int_{-\infty}^{+\infty} \frac{x e^{ax}}{1+e^x} dx = -\frac{\pi \cos a\pi}{\sin a\pi} \int_{-\infty}^{+\infty} \frac{e^{ax}}{1+e^x} dx = -\frac{\pi \cos a\pi}{\sin a\pi} \cdot \frac{\pi}{\sin a\pi} = -\frac{\pi^2 \cos a\pi}{\sin^2 a\pi}.$$

Example 3.6 Compute the complex line integral

$$\oint_{|z|=2} \frac{1}{\left(z - \frac{\pi}{2}\right) \cos z} dz.$$

The analytic function $\cos z$ has the simple zeros

$$z = \frac{\pi}{2} + n\pi, \quad n \in \mathbb{Z}.$$

Hence the given integrand has *infinitely* many (simple) poles outside $|z| = 2$. Inside $|z| = 2$ the integrand has a *simple pole* at $z = -\frac{\pi}{2}$ and a *double pole* at $z = +\frac{\pi}{2}$. Except for the poles, the function

$$f(z) = \frac{1}{\left(z - \frac{\pi}{2}\right) \cos z}$$

is analytic. Then by the *residue theorem*,

$$\oint_{|z|=2} \frac{dz}{\left(z - \frac{\pi}{2}\right) \cos z} = 2\pi i \left\{ \operatorname{res} \left(f; \frac{\pi}{2} \right) + \operatorname{res} \left(f; -\frac{\pi}{2} \right) \right\}.$$

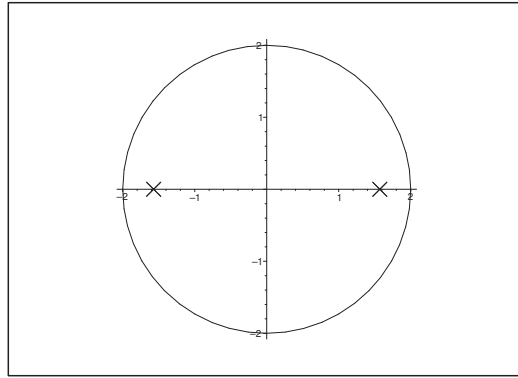
Figure 3: The curve $|z| = 2$ with the two poles insider.

Determination of $\operatorname{res}\left(f; -\frac{\pi}{2}\right)$. The pole $z = -\frac{\pi}{2}$ is *simple*. Apply RULE II where e.g.

$$A(z) = \frac{1}{z - \frac{\pi}{2}} \quad \text{and} \quad B(z) = \cos z.$$

Then

$$\operatorname{res}\left(f; -\frac{\pi}{2}\right) = \frac{A\left(-\frac{\pi}{2}\right)}{B'\left(-\frac{\pi}{2}\right)} = \frac{1}{\left(-\frac{\pi}{2} - \frac{\pi}{2}\right) \cdot \left(-\sin\left(-\frac{\pi}{2}\right)\right)} = -\frac{1}{\pi}.$$

ALTERNATIVELY we apply RULE I. Then

$$\begin{aligned} \operatorname{res}\left(f; -\frac{\pi}{2}\right) &= \lim_{z \rightarrow -\frac{\pi}{2}} \frac{1}{z - \frac{\pi}{2}} \cdot \frac{z + \frac{\pi}{2}}{\cos z} = \frac{1}{-\frac{\pi}{2} - \frac{\pi}{2}} \cdot \frac{1}{\lim_{z \rightarrow -\frac{\pi}{2}} \frac{\cos z - \cos\left(-\frac{\pi}{2}\right)}{z - \left(-\frac{\pi}{2}\right)}} \\ &= -\frac{1}{\pi} \cdot \frac{1}{\lim_{z \rightarrow -\frac{\pi}{2}} \frac{d}{dz} \cos z} = -\frac{1}{\pi} \cdot \frac{1}{[-\sin z]_{z=-\frac{\pi}{2}}} = -\frac{1}{\pi}. \end{aligned}$$

Determination of $\operatorname{res}\left(f; \frac{\pi}{2}\right)$. Here we shall demonstrate a seldom application of RULE III, where

$$A(z) = 1 \quad \text{and} \quad B(z) = \left(z - \frac{\pi}{2}\right) \cos z.$$

Then $A' = 0$, and

$$B'(z) = \cos z - \left(z - \frac{\pi}{2}\right) \sin z,$$

$$B''(z) = -2 \sin z - \left(z - \frac{\pi}{2}\right) \cos z, \quad B'' = -2,$$

$$B'''(z) = -3 \cos z + \left(z - \frac{\pi}{2}\right) \sin z, \quad B''' = 0,$$

hence

$$\operatorname{res}\left(f; \frac{\pi}{2}\right) = \frac{6A'B'' - 2AB'''}{3(B'')^2} = \frac{6 \cdot 0 \cdot (-2) - 2 \cdot 1 \cdot 0}{3 \cdot (-2)^2} = 0.$$

ALTERNATIVELY (and more difficult) we use RULE I and *l'Hospital's rule* (or possibly *o*-technique) with

$$g(z) = \frac{z - \frac{\pi}{2}}{\cos z} = \frac{z - \frac{\pi}{2}}{\sin\left(\frac{\pi}{2} - z\right)} = -\frac{z - \frac{\pi}{2}}{\sin\left(z - \frac{\pi}{2}\right)},$$

hence

$$g\left(\frac{\pi}{2}\right) = -\lim_{z \rightarrow \frac{\pi}{2}} \frac{z - \frac{\pi}{2}}{\sin\left(z - \frac{\pi}{2}\right)} = -1,$$

and

$$\frac{g(z) - g\left(\frac{\pi}{2}\right)}{z - \frac{\pi}{2}} = \frac{\frac{z - \frac{\pi}{2}}{\cos z} + 1}{z - \frac{\pi}{2}} = \frac{z - \frac{\pi}{2} + \cos z}{\left(z - \frac{\pi}{2}\right) \cdot \cos z} = \frac{T(z)}{N(z)}.$$

Since $\cos z$ has a simple zero at $z = \frac{\pi}{2}$, the denominator

$$N(z) = \left(z - \frac{\pi}{2}\right) \cdot \cos z$$

has a double zero at $z = \frac{\pi}{2}$. The series expansion of $\cos z$ from $z = \frac{\pi}{2}$ is given by

$$\cos z = -\left(z - \frac{\pi}{2}\right) + \frac{1}{3!}\left(z - \frac{\pi}{2}\right)^3 + o\left(\left(z - \frac{\pi}{2}\right)^3\right),$$

hence

$$T(z) = \frac{1}{6}\left(z - \frac{\pi}{2}\right)^3 + o\left(\left(z - \frac{\pi}{2}\right)^3\right),$$

$$N(z) = -\left(z - \frac{\pi}{2}\right)^2 + o\left(\left(z - \frac{\pi}{2}\right)^2\right),$$

and we conclude that

$$\frac{T(z)}{N(z)} = -\frac{1}{6}\left(z - \frac{\pi}{2}\right) + o\left(\left(z - \frac{\pi}{2}\right)^1\right),$$

and therefore,

$$\operatorname{res}\left(f; \frac{\pi}{2}\right) = \frac{1}{1!}g'\left(\frac{\pi}{2}\right) = \lim_{z \rightarrow \frac{\pi}{2}} \frac{g(z) - g\left(\frac{\pi}{2}\right)}{z - \frac{\pi}{2}} = \lim_{z \rightarrow \frac{\pi}{2}} \frac{T(z)}{N(z)} = 0.$$

ALTERNATIVELY we apply *l'Hospital's rule* recursively, since

$$\begin{aligned} T(z) &= z - \frac{\pi}{2} + \cos z, & T\left(\frac{\pi}{2}\right) &= 0, \\ N(z) &= \left(z - \frac{\pi}{2}\right) \cos z, & N\left(\frac{\pi}{2}\right) &= 0, \\ \\ T'(z) &= 1 - \sin z, & T'\left(\frac{\pi}{2}\right) &= 0, \\ N'(z) &= \cos z - \left(z - \frac{\pi}{2}\right) \sin z, & N'\left(\frac{\pi}{2}\right) &= 0, \\ \\ T''(z) &= -\cos z, & T''\left(\frac{\pi}{2}\right) &= 0, \\ N''(z) &= -2 \sin z - \left(z - \frac{\pi}{2}\right) \cos z, & N''\left(\frac{\pi}{2}\right) &= -2, \end{aligned}$$

and we conclude again that

$$\lim_{z \rightarrow \frac{\pi}{2}} \frac{T(z)}{N(z)} = \frac{0}{-2} = 0.$$

Finally, we get summing up,

$$\oint_{|z|=2} \frac{dz}{\left(z - \frac{\pi}{2}\right) \cos z} = 2\pi i \left\{ \operatorname{res}\left(f; \frac{\pi}{2}\right) + \operatorname{res}\left(f; -\frac{\pi}{2}\right) \right\} = 2\pi i \left\{ 0 - \frac{1}{\pi} \right\} = -2i.$$

Please click the advert



DIVERSE - INNOVATIVE - INTERNATIONAL

Are you considering a European business degree?

Copenhagen Business School is one of the largest business schools in Northern Europe with more than 15,000 students from Europe, North America, Australia and Asia.

Are you curious to know how a modern European business school competes with a diverse, innovative and international study environment?

Please visit Copenhagen Business School at www.cbs.dk



Copenhagen Business School
HÅNDELSHØJSKOLEN

Diversity creating knowledge



Example 3.7 Compute the complex line integral

$$\oint_{|z|=2} \frac{e^{2z} - e^{z+1}}{(z-1)^5} dz.$$

The integrand has a pole of at most order ≤ 5 at the point $z = 1$ (the order is actually 4) inside $|z| = 2$, so we get from RULE I that

$$\begin{aligned} \oint_{|z|=2} \frac{e^{2z} - e^{z+1}}{(z-1)^5} dz &= 2\pi i \operatorname{res}(f; 1) = \frac{2\pi i}{4!} \lim_{z \rightarrow 1} \frac{d^4}{dz^4} (e^{2z} - e^{z+1}) \\ &= \frac{\pi i}{12} \cdot (2^4 e^2 - e^{1+1}) = \frac{15\pi i}{12} e^2 = \frac{5\pi e^2}{4} \cdot i. \end{aligned}$$

ALTERNATIVELY we may apply RULE I with $q = 4$ instead,

$$\oint_{|z|=2} \frac{e^{2z} - e^{z+1}}{(z-1)^5} dz = 2\pi i \cdot \operatorname{res}(f; 1) = \frac{2\pi i}{3!} \lim_{z \rightarrow 1} \frac{d^3}{dz^3} \left(\frac{e^{2z} - e^{z+1}}{z-1} \right).$$

It is possible with some difficulty to get through these computations, but it is not worth it here. The message is that we gain a lot by pretending a higher order.

ALTERNATIVELY we use that we here also have

$$\operatorname{res}(f; 1) = -\operatorname{res}(f; \infty).$$

It is actually possible directly to find $\operatorname{res}(f; \infty)$, but again the computations are rather difficult.

ALTERNATIVELY we expand

$$g(z) = e^{2z} - e^{z+1} \quad \text{ud fra } z = 1.$$

as a series. The Taylor coefficients are

$$\begin{array}{ll} g(z) = e^{2z} - e^{z+1}, & g(1) = 0, \\ g'(z) = 2e^{2z} - e^{z+1}, & g'(1) = e^2, \\ g''(z) = 4e^{2z} - e^{z+1}, & g''(1) = 3e^2, \\ g^{(3)}(z) = 8e^{2z} - e^{z+1}, & g^{(3)}(1) = 7e^2, \\ g^{(4)}(z) = 16e^{2z} - e^{z+1}, & g^{(4)}(1) = 15e^2, \end{array}$$

so the Laurent series expansion becomes

$$f(z) = \frac{g(z)}{(z-1)^5} = \frac{1}{(z-1)^5} \left\{ 0 + \frac{e^2}{1!} (z-1) + \frac{3e^2}{2!} (z-1)^2 + \frac{7e^2}{3!} (z-1)^3 + \frac{15e^2}{4!} (z-1)^4 + \dots \right\}.$$

From here we get

$$\operatorname{res}(f; 1) = a_{-1} = \frac{15e^2}{4!} = \frac{15e^2}{24} = \frac{5e^2}{8},$$

hence by insertion,

$$\oint_{|z|=2} \frac{e^{2z} - e^{z+1}}{(z-1)^5} dz = 2\pi i a_{-1} = \frac{5\pi e^2}{4} \cdot i.$$

Example 3.8 Given the function

$$f(z) = (a + bz^2)^{-m},$$

where $z \in \mathbb{C}$ is a complex variable, and $a, b \in \mathbb{R}_+$ are positive, real numbers, and $m \in \mathbb{N}$ is a positive integer.

- (a) Find the singular points of the function $f(z)$, and determine their type.
 (b) We shall expand $f(z)$ as a Laurent series in the set

$$0 < \left| z - i\sqrt{\frac{a}{b}} \right| < R.$$

Find the largest possible R .

Then find the Laurent series and prove in particular that

$$a_{-1} = \frac{(-1)^{m-1}(2m-2)!}{b^m \{(m-1)!\}^2 \left(2i\sqrt{\frac{a}{b}}\right)^{2m-1}}.$$

- (c) Prove that

$$\lim_{R \rightarrow +\infty} \int_{C_R} \frac{dz}{(a + bz^2)^m} = 0,$$

where C_R denotes the half circle $z = Re^{i\theta}$, $0 \leq \theta \leq \pi$.

- (d) Find

$$I = \int_0^{+\infty} \frac{dx}{(a + bx^2)^m}.$$

- (a) It follows from

$$a + bz^2 = b \left(z^2 + \frac{a}{b} \right) = b \left(z - i\sqrt{\frac{a}{b}} \right) \left(z + i\sqrt{\frac{a}{b}} \right),$$

that

$$f(z) = \frac{1}{(a + bz^2)^m} = \frac{1}{b^m \left(z - i\sqrt{\frac{a}{b}} \right)^m \left(z + i\sqrt{\frac{a}{b}} \right)^m},$$

showing that $z = \pm i\sqrt{\frac{a}{b}}$ are poles of order m .

- (b) Now,

$$g(z) = \left(z - i\sqrt{\frac{a}{b}} \right)^m f(z) = \frac{1}{b^m \left(z + i\sqrt{\frac{a}{b}} \right)^m},$$

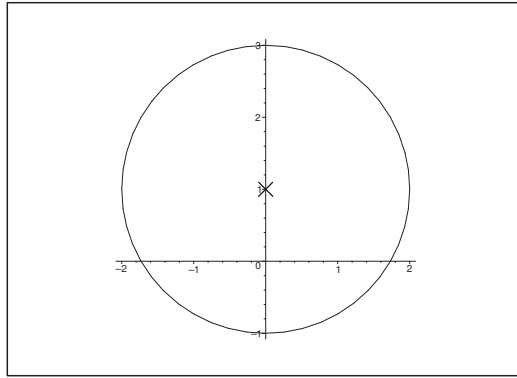
Figure 4: The domain of analyticity for $a = b > 0$.

so it follows from the figure that $g(z)$ is analytic in the open disc

$$\left\{ z \in \mathbb{C} \mid \left| z - i\sqrt{\frac{a}{b}} \right| < 2\sqrt{\frac{a}{b}} \right\}.$$

Hence, $g(z)$ has a Taylor expansion from the centrum $z_0 = i\sqrt{\frac{a}{b}}$ of this disc, and the maximum radius is $R = 2\sqrt{\frac{a}{b}}$. We conclude that $f(z)$ has a Laurent series expansion in the set

$$0 < \left| z - i\sqrt{\frac{a}{b}} \right| < 2\sqrt{\frac{a}{b}},$$

where $R = 2\sqrt{\frac{a}{b}}$ is maximum.

Assume that

$$0 < \left| z - i\sqrt{\frac{a}{b}} \right| < 2\sqrt{\frac{a}{b}}.$$

Then

$$\begin{aligned} f(z) &= \frac{1}{(a + bz^2)^m} = \frac{1}{b^m \left(z - i\sqrt{\frac{a}{b}} \right)^m \left(z + i\sqrt{\frac{a}{b}} \right)^m} \\ &= \frac{1}{b^m \left(z - i\sqrt{\frac{a}{b}} \right)^m \left(2i\sqrt{\frac{a}{b}} + z - i\sqrt{\frac{a}{b}} \right)^m} \\ &= \frac{1}{b^m \left(z - i\sqrt{\frac{a}{b}} \right)^m} \cdot \frac{1}{\left(2i\sqrt{\frac{a}{b}} \right)^m} \cdot \left\{ 1 + \frac{1}{2i\sqrt{\frac{a}{b}}} \left(z - i\sqrt{\frac{a}{b}} \right) \right\}^{-m}, \end{aligned}$$

hence by the binomial formula,

$$f(z) = \frac{1}{b^m \left(z - i\sqrt{\frac{a}{b}}\right)^m} \cdot \frac{1}{\left(2i\sqrt{\frac{a}{b}}\right)^m} \sum_{n=0}^{+\infty} \binom{-m}{n} \left\{ \frac{1}{2i\sqrt{\frac{a}{b}}} \left(z - i\sqrt{\frac{a}{b}}\right) \right\}^n.$$

Since

$$\begin{aligned} \binom{-m}{n} &= \frac{(-m)(-m-1)\cdots(-m-n+1)}{1 \cdot 2 \cdots n} \\ &= (-1)^n \cdot \frac{(m+n-1)(m+n-2)\cdots m}{n!} \cdot \frac{(m-1)!}{(m-1)!} \\ &= (-1)^n \cdot \frac{(m+n-1)!}{n!(m-1)!} = (-1)^n \binom{n+m-1}{n}, \end{aligned}$$

Please click the advert



Sharp Minds - Bright Ideas!

Employees at FOSS Analytical A/S are living proof of the company value - First - using new inventions to make dedicated solutions for our customers. With sharp minds and cross functional teamwork, we constantly strive to develop new unique products - Would you like to join our team?

FOSS works diligently with innovation and development as basis for its growth. It is reflected in the fact that more than 200 of the 1200 employees in FOSS work with Research & Development in Scandinavia and USA. Engineers at FOSS work in production, development and marketing, within a wide range of different fields, i.e. Chemistry, Electronics, Mechanics, Software, Optics, Microbiology, Chemometrics.

We offer
A challenging job in an international and innovative company that is leading in its field. You will get the opportunity to work with the most advanced technology together with highly skilled colleagues.

Read more about FOSS at www.foss.dk - or go directly to our student site www.foss.dk/sharpminds where you can learn more about your possibilities of working together with us on projects, your thesis etc.

The Family owned FOSS group is the world leader as supplier of dedicated, high-tech analytical solutions which measure and control the quality and production of agricultural, food, pharmaceutical and chemical products. Main activities are initiated from Denmark, Sweden and USA with headquarters domiciled in Hillerød, DK. The products are marketed globally by 23 sales companies and an extensive net of distributors. In line with the corevalue to be 'First', the company intends to expand its market position.

Dedicated Analytical Solutions

FOSS
 Slangerupgade 69
 3400 Hillerød
 Tel. +45 70103370
www.foss.dk



it follows by insertion that

$$\begin{aligned}
 f(z) &= \frac{1}{b^m \left(z - i\sqrt{\frac{a}{b}}\right)^m} \cdot \frac{1}{\left(2i\sqrt{\frac{a}{b}}\right)^m} \times \\
 &\quad \times \sum_{n=0}^{+\infty} (-1)^n \frac{(m+n-1)!}{n!(m-1)!} \cdot \frac{1}{\left(2i\sqrt{\frac{a}{b}}\right)^n} \left(z - i\sqrt{\frac{a}{b}}\right)^n \\
 &= \sum_{n=0}^{+\infty} \frac{(-1)^m}{b^m} \cdot \frac{(m+n-1)!}{n!(m-1)!} \cdot \frac{1}{\left(2i\sqrt{\frac{a}{b}}\right)^{m+n}} \left(z - i\sqrt{\frac{a}{b}}\right)^{n-m} \\
 &= \sum_{p=-m}^{+\infty} \frac{(-1)^{m+p}}{b^m} \cdot \frac{2m+p-1!}{(m+p)!(m-1)!} \cdot \frac{1}{\left(2i\sqrt{\frac{a}{b}}\right)^{2m+p}} \left(z - i\sqrt{\frac{a}{b}}\right)^p \\
 &= \sum_{p=-m}^{+\infty} a_p \left(z - i\sqrt{\frac{a}{b}}\right)^p,
 \end{aligned}$$

which is the Laurent series expansion of $f(z)$ in the set

$$0 < \left|z - i\sqrt{\frac{a}{b}}\right| < 2\sqrt{\frac{a}{b}},$$

of centrum $i\sqrt{\frac{a}{b}}$ and radius $R = 2\sqrt{\frac{a}{b}}$.

In particular, a_{-1} for $p = -1$, i.e.

$$a_{-1} = \frac{1}{b^m} \cdot \frac{(2m-2)!}{(m-1)!(m-1)!} \cdot \frac{(-1)^{m-1}}{\left(2i\sqrt{\frac{a}{b}}\right)^{2m-1}} = \frac{1}{b^m} \binom{2m-2}{m-1} \cdot \frac{1}{\left(2\sqrt{\frac{a}{b}}\right)^{2m-1}} \cdot \frac{1}{i}.$$

(c) We get from

$$\frac{1}{|a + bz^2|} \leq \frac{1}{(bR^2 - a)^m} \quad \text{for } |z| = R > \sqrt{\frac{a}{b}},$$

the estimate

$$\left| \lim_{R \rightarrow +\infty} \int_{C_R} \frac{dz}{(a + bz^2)^m} \right| \leq \lim_{R \rightarrow +\infty} \frac{1}{(bR^2 - a)^m} \cdot \pi R = 0,$$

proving that

$$\lim_{R \rightarrow +\infty} \int_{C_R} \frac{dz}{(a + bz^2)^m} = 0.$$

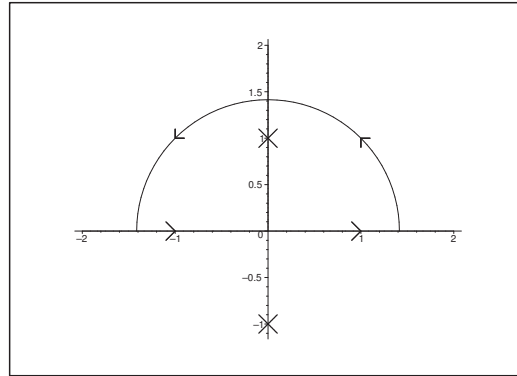
Figure 5: The curves $\Gamma_{\sqrt{2}}$ and $C_{\sqrt{2}}$ for $a = b$.

(d) Denote by Γ_R , where $R > \sqrt{\frac{a}{b}}$, the closed curve shown on the figure for $a = b > 0$ and $R = \sqrt{2} >$

$\sqrt{\frac{a}{b}} = \sqrt{\frac{1}{1}} = 1$. Then

$$\begin{aligned} \oint_{\Gamma_R} \frac{dz}{(a+bz^2)^m} &= 2\pi i \operatorname{res}\left(f; i\sqrt{\frac{a}{b}}\right) = 2\pi i \cdot a_{-1} = \frac{2\pi}{b^m} \binom{2m-2}{m-1} \frac{1}{\left(2\sqrt{\frac{a}{b}}\right)^{2m-1}} \\ &= \frac{2\pi}{b^m} \binom{2m-2}{m-1} \frac{1}{2^{2m-1}} \cdot \frac{b^m}{a^m} \sqrt{\frac{a}{b}} = \frac{\pi}{2^{2m-2}a^m} \binom{2m-2}{m-1} \sqrt{\frac{a}{b}}. \end{aligned}$$

On the other hand,

$$\begin{aligned} \lim_{R \rightarrow +\infty} \oint_{\Gamma_R} \frac{dz}{(a+bz^2)^m} &= \lim_{R \rightarrow +\infty} \int_{C_R} \frac{dz}{(a+bz^2)^m} + \lim_{R \rightarrow +\infty} \int_{-R}^R \frac{dx}{(a+bx^2)^m} \\ &= \lim_{R \rightarrow +\infty} 2 \int_0^{+\infty} \frac{dx}{(a+bx^2)^m} = 2 \int_0^{+\infty} \frac{dx}{(a+bx^2)^m}, \end{aligned}$$

and we conclude that

$$I = \int_0^{+\infty} \frac{dx}{(a+bx^2)^m} = \frac{2\pi}{2^{2m}a^m} \binom{2m-2}{m-1} \sqrt{\frac{a}{b}},$$

because the improper integral of course is convergent.

ALTERNATIVELY, the difference of the degrees is $2m \geq 2$ where the denominator is dominating, and since none of the poles $\pm i\sqrt{\frac{a}{b}}$ lie on the x -axis, we conclude by a theorem that

$$\begin{aligned} I &= \int_0^{+\infty} \frac{dx}{(a+bx^2)^m} = \frac{1}{2} \int_{-\infty}^{+\infty} \frac{dx}{(a+bx^2)^m} = \frac{1}{2} \cdot 2\pi i \cdot \text{res} \left(\frac{1}{(a+bz^2)^m}; i\sqrt{\frac{a}{b}} \right) \\ &= \pi i \cdot \text{res} \left(\frac{1}{b^m \left(z - i\sqrt{\frac{a}{b}}\right)^m \left(z + i\sqrt{\frac{a}{b}}\right)^m}; i\sqrt{\frac{a}{b}} \right) \\ &= \frac{\pi i}{b^m} \cdot \frac{1}{(m-1)!} \lim_{z \rightarrow i\sqrt{\frac{a}{b}}} \frac{d^{m-1}}{dz^{m-1}} \left\{ \frac{1}{\left(z + i\sqrt{\frac{a}{b}}\right)^m} \right\}, \end{aligned}$$

Please click the advert







www.1calendar.dk

thus

$$\begin{aligned}
 I &= \int_0^{+\infty} \frac{dx}{(a+bx^2)^m} = \frac{\pi i}{b^m} \cdot \frac{1}{(m-1)!} \lim_{z \rightarrow i\sqrt{\frac{a}{b}}} \frac{-m(-m-1)\cdots(-m-m+2)}{\left(z+i\sqrt{\frac{a}{b}}\right)^{m+m-1}} \\
 &= \frac{\pi i}{b^m} \cdot \frac{(-1)^{m-1}}{(m-1)!} \cdot \frac{(2m-2)!}{(m-1)!} \cdot \frac{1}{\left(2i\sqrt{\frac{a}{b}}\right)^{2m-1}} \\
 &= \frac{\pi i}{b^m} \cdot (-1)^{m-1} \binom{2m-2}{m-1} \cdot \frac{1}{2^{2m-1} \cdot i^{2m-1} \cdot \frac{a^m}{b^m} \sqrt{\frac{a}{b}}} \\
 &= \frac{\pi}{b^m} \cdot \frac{(-1)^{m-1}}{i^{2m-2}} \binom{2m-2}{m-1} \cdot \frac{1}{2^{2m-1}} \cdot \frac{b^m}{a^m} \sqrt{\frac{a}{b}} = \frac{2\pi}{2^{2m} a^m} \binom{2m-2}{m-1} \sqrt{\frac{a}{b}}.
 \end{aligned}$$

Example 3.9 Given two polynomials $P(z)$ and $Q(z)$, where the degree of $Q(z)$ is at least 1 bigger than the degree of $P(z)$. Let z_1, \dots, z_n be the different roots of $Q(z)$. Then it can be proved that the inverse Laplace transform of

$$F(z) = \frac{P(z)}{Q(z)}$$

is given by

$$(8) \quad f(t) = \sum_{j=1}^n \operatorname{res}(e^{zt}F(z); z_j), \quad \text{for } t \geq 0,$$

where we consider the variable t as a parameter.

Assume given the formula (8). Find the inverse Laplace transform $f(t)$, $t \geq 0$, of

$$F(z) = \frac{1}{(z^2+1)^2}.$$

Describe the function $f(t)$ in the real, i.e. such that the imaginary unit does not occur.

Since

$$F(z) = \frac{1}{(z^2+1)^2}$$

has the two double poles $\pm i$, we shall only find

$$f(t) = \operatorname{res}\left(\frac{e^{zt}}{(z^2+1)^2}; i\right) + \operatorname{res}\left(\frac{e^{zt}}{(z^2+1)^2}; -i\right).$$

We get by RULE I,

$$\begin{aligned}
 \operatorname{res}\left(\frac{e^{zt}}{(z^2+1)^2}; i\right) &= \frac{1}{1!} \lim_{z \rightarrow i} \frac{d}{dz} \left(\frac{e^{zt}}{(z+i)^2}\right) = \lim_{z \rightarrow i} \left\{ \frac{t e^{zt}}{(z+i)^2} - \frac{2 e^{zt}}{(z+i)^3} \right\} \\
 &= \frac{t e^{it}}{(2i)^2} - \frac{2 e^{it}}{(2i)^3} = -\frac{1}{4} t e^{it} - \frac{i}{4} e^{it},
 \end{aligned}$$

and

$$\begin{aligned} \operatorname{res} \left(\frac{e^{zt}}{(z^2+1)^2}; -i \right) &= \frac{1}{1!} \lim_{z \rightarrow -i} \frac{d}{dz} \left(\frac{e^{zt}}{(z-i)^2} \right) = \lim_{z \rightarrow -i} \left\{ \frac{t e^{zt}}{(z-i)^2} - \frac{2 e^{zt}}{(z-i)^3} \right\} \\ &= \frac{t e^{-it}}{(-2i)^2} - \frac{2 e^{-it}}{(-2i)^3} = -\frac{1}{4} t e^{-it} + \frac{i}{4} e^{it}, \end{aligned}$$

hence by insertion into (8),

$$\begin{aligned} f(t) &= -\frac{1}{4} t e^{it} - \frac{i}{4} e^{it} - \frac{1}{4} t e^{-it} + \frac{i}{4} e^{-it} = -\frac{1}{2} t \left(\frac{1}{2} \{e^{it} + e^{-it}\} \right) + \frac{1}{2} \cdot \frac{1}{2i} \{e^{it} - e^{-it}\} \\ &= -\frac{1}{2} t \cos t + \frac{1}{2} \sin t. \end{aligned}$$

ALTERNATIVELY we may apply RULE III, thus

$$\operatorname{res}(f; z_0) = \frac{6A'B'' - 2AB'''}{3(B'')^2}.$$

If we put

$$A(z) = e^{zt} \quad \text{and} \quad B(z) = (z^2+1)^2 = z^4 + 2z^2 + 1,$$

then

$$\begin{array}{lll} A(z) = e^{zt}, & A(i) = e^{it}, & A(-i) = e^{-it}, \\ A'(z) = t e^{zt}, & A'(i) = t e^{it}, & \\ B(z) = z^4 + 2z^2 + 1, & B(i) = 0, & B(-i) = 0, \\ B'(z) = 4z^3 + 4z, & B'(i) = 0, & B'(-i) = 0, \\ B''(z) = 12z^2 + 4, & B''(i) = -8, & B''(-i) = -8, \\ B^{(3)}(z) = 24z, & B^{(3)}(i) = 24i, & B^{(3)}(-i) = -24i, \end{array}$$

hence,

$$\operatorname{res} \left(\frac{e^{zt}}{(z^2+1)^2}; i \right) = \frac{6t e^{it} \cdot (-8) - 2e^{it} \cdot 24i}{3(-8)^2} = -\frac{1}{4} t e^{it} - \frac{i}{4} e^{it},$$

and

$$\operatorname{res} \left(\frac{e^{zt}}{(z^2+1)^2}; -i \right) = \frac{6t e^{-it} \cdot (-8) - 2e^{-it} \cdot (-24i)}{3(-8)^2} = -\frac{1}{4} t e^{-it} + \frac{i}{4} e^{-it},$$

and we proceed as above.

Example 3.10 (a) Find the complete solutions of the differential equation

$$(9) \quad f'(z) = \frac{1}{z} f(z) - \frac{1}{z+1},$$

in the domain $\Omega = \{z \in \mathbb{C} \mid |z| > 1\}$.

HINT: Find e.g. $f(z) = \sum a_n z^n$ as a Laurent series solution of (9) in Ω . It will be advantageous to use the Laurent series expansion of $\frac{1}{z+1}$ in Ω .

(b) Prove that there exists precisely one solution $f_0(z)$ of (9) in Ω , such that $f_0(z)$ is bounded at ∞ . Express $f_0(z)$ by elementary functions without using sums.

(c) Compute the line integral

$$\oint_{|z|=2} f_0(z) dz.$$

(a) It follows by inspection that if $z \neq 0, -1$, then

$$-\frac{1}{z+1} \cdot \frac{1}{z} = \frac{f'(z)}{z} - \frac{1}{z^2} f(z) = \frac{z f'(z) - 1 \cdot f(z)}{z^2} = \frac{d}{dz} \left(\frac{f(z)}{z} \right).$$

Thus, for $|z| > 1$,

$$\frac{f(z)}{z} = c - \int \frac{1}{z} \cdot \frac{1}{z+1} dz = c + \int \left(\frac{1}{1+z} - \frac{1}{z} \right) dz = c + \text{Log} \left(\frac{z+1}{z} \right),$$

because we only have

$$\frac{z+1}{z+0} = -\alpha, \quad \alpha \in \mathbb{R}_+ \cup \{0\},$$

when $z = \frac{1}{1+\alpha} \in]0, 1]$. Hence the function

$$\text{Log} \left(\frac{z+1}{z} \right) = \text{Log} \left(1 + \frac{1}{z} \right)$$

is analytic in Ω . The complete solution is then

$$f(z) = c \cdot z + z \cdot \text{Log} \left(1 + \frac{1}{z} \right), \quad |z| > 1, \quad c \in \mathbb{C}.$$

ALTERNATIVELY, assume that $f(z)$ has a Laurent series expansion

$$f(z) = \sum_{n=-\infty}^{+\infty} a_n z^n \quad \text{for } |z| > 1.$$

Then by insertion,

$$f'(z) - \frac{1}{z} f(z) = \sum_{n=-\infty}^{+\infty} n a_n z^{n-1} - \sum_{n=-\infty}^{+\infty} a_n z^{n-1} = \sum_{n=-\infty}^{+\infty} (n-1) a_n z^{n-1}.$$

Furthermore,

$$-\frac{1}{z+1} = -\frac{1}{z} \cdot \frac{1}{1+\frac{1}{z}} = -\frac{1}{z} \sum_{n=0}^{+\infty} (-1)^n \cdot \frac{1}{z^n} = \sum_{n=0}^{+\infty} (-1)^{n-1} z^{-n-1},$$

so if we on the left hand side write $-n$ instead of n , then we get the following equation,

$$\sum_{n=-\infty}^{+\infty} (-n-1)a_{-n}z^{-n-1} = -\sum_{n=0}^{+\infty} (-1)^n z^{-n-1}.$$

The Laurent series expansion is unique, so we conclude that

$$\begin{cases} (-n-1)a_{-n} = -(-1)^n, & \text{thus } a_{-n} = \frac{(-1)^n}{n+1}, \quad n \in \mathbb{N}_0, \\ a_1 \text{ an indeterminate,} & \text{(corresponding to } n = -1), \\ a_n = 0 & \text{for } n \geq 2. \end{cases}$$

The formal series is given by

$$a_1 z + \sum_{n=0}^{+\infty} \frac{(-1)^n}{n+1} \cdot \frac{1}{z^n} = a_1 z + z \sum_{n=1}^{+\infty} \frac{(-1)^{n+1}}{n} \cdot \frac{1}{z^n} = a_1 z + z \cdot \text{Log} \left(1 + \frac{1}{z} \right),$$

which of course is convergent for $\left| \frac{1}{z} \right| < 1$, i.e. for $|z| > 1$.

Please click the advert

**Design your
own future at
MAN Diesel**

www.mandiesel.com

MAN Diesel – Powering the World



Download free books at BookBooN.com

(b) If $|z| > 1$, then

$$z \cdot \operatorname{Log} \left(1 + \frac{1}{z} \right) = z \sum_{n=1}^{+\infty} \frac{(-1)^{n+1}}{n} \cdot \frac{1}{z^n} = \sum_{n=0}^{+\infty} \frac{(-1)^n}{n+1} \cdot \frac{1}{z^n},$$

and it follows that

$$\lim_{z \rightarrow \infty} z \cdot \operatorname{Log} \left(\frac{z+1}{z} \right) = \frac{(-1)^0}{1+0} = 1.$$

When $z \rightarrow \infty$, the term $c \cdot z$ is only bounded if $c = 0$, so the wanted solution is

$$f_0(z) = z \cdot \operatorname{Log} \left(1 + \frac{1}{z} \right).$$

(c) The circle $|z| = 2$ lies in the domain of analyticity Ω , so it follows from the Laurent series expansion that

$$\oint_{|z|=2} f_0(z) dz = \oint_{|z|=2} z \cdot \operatorname{Log} \left(1 + \frac{1}{z} \right) dz = 2\pi i a_{-1} = 2\pi i \cdot \left(-\frac{1}{2} \right) = -\pi i.$$

Example 3.11 Given the differential equation

$$(10) \quad (z^2 - z) f''(z) + (5z - 4) f'(z) + 3 f(z) = 0.$$

- (a) Assume that (10) has a Laurent series solution $f(z) = \sum a_n z^n$. Derive a recursion formula for the coefficients a_n , and prove that $a_n = 0$ for $n \leq 4$.
- (b) Then find all Laurent series solutions of (10), and express each of them by elementary functions.
- (c) Find the Laurent series solutions which have a pole at 0, determine the order of this pole and the residuum at $z = 0$.

First method. *Inspection.* This solution method does not follow the text, so we must be careful to have answered all questions.

We get for $z \neq 0$ by some simple manipulations that

$$\begin{aligned} 0 &= (z^2 - z) f''(z) + (5z - 4) f'(z) + 3 f(z) \\ &= \{ (z^2 - z) f''(z) + (2z - 1) f'(z) \} + \{ (3z - 3) f'(z) + 3 f(z) \} \\ &= \frac{d}{dz} \{ (z^2 - z) f'(z) \} + \frac{d}{dz} \{ 3(z - 1) f(z) \} \\ &= \frac{d}{dz} \left\{ \frac{z-1}{z^2} (z^3 f'(z) + 3z^2 f(z)) \right\} \\ &= \frac{d}{dz} \left\{ \frac{z-1}{z^2} \frac{d}{dz} (z^3 f(z)) \right\}. \end{aligned}$$

Hence by an integration,

$$\frac{z-1}{z} \frac{d}{dz} (z^3 f(z)) = c_1, \quad z \in \mathbb{C} \setminus \{0\}, \quad c_1 \in \mathbb{C},$$

so $z \neq 0$ and $z \neq 1$,

$$\frac{d}{dz} (z^3 f(z)) = \frac{c_1 z^3}{z-1} = c_1(z+1) + \frac{c_1}{z-1}.$$

When we integrate $\frac{c_1}{z-1}$, we have two possibilities:

- 1) In the first case we shall check the choice of $c_1 \operatorname{Log}(z-1)$. This function has a branch cut along the half line $] -\infty, +1[$. In particular, *every* circle of centrum at 0 will intersect $] -\infty[$ at least once. This means that $\operatorname{Log}(1-z)$ does not have any Laurent series expansion in any annulus, so we have to reject this possibility of solution.
- 2) The second choice is $c_1 \operatorname{Log}(1-z)$ of the branch cut along the half line $]1, +\infty[$. In this case we already know that

$$c_1 \operatorname{Log}(1-z) = -c_1 \sum_{n=1}^{+\infty} \frac{1}{n} z^n \quad \text{for } |z| < 1,$$

and we even get a power series expansion. Hence, we shall choose this primitive in the following.

We get by another integration that

$$z^3 f(z) = c_1 \left(\frac{z^2}{2} + z \right) + c_1 \operatorname{Log}(1-z) + c_2, \quad z \in \mathbb{C} \setminus (\{0\} \cup [1, +\infty[),$$

hence

$$f(z) = \frac{c_2}{z^3} + \frac{c_1}{z^3} \operatorname{Log}(1-z) + \frac{c_1}{z^2} + \frac{c_1}{2z}, \quad z \in \mathbb{C} \setminus (\{0\} \cup [1, +\infty[).$$

When we insert the power series expansion, we get for $0 < |z| < 1$ that

$$\begin{aligned} f(z) &= \frac{c_2}{z^3} + \frac{c_1}{z^3} \left\{ -\sum_{n=1}^{+\infty} \frac{1}{n} z^n + z + \frac{1}{2} z^2 \right\} = \frac{c_2}{z^3} + \frac{c_1}{z^3} \left\{ -\sum_{n=3}^{+\infty} \frac{1}{n} z^n \right\} \\ &= \frac{c_2}{z^3} - c_1 \sum_{n=0}^{+\infty} \frac{1}{n+3} z^n, \quad 0 < |z| < 1. \end{aligned}$$

In particular, $a_0 = 0$ for $n \leq -4$, and if $c_2 \neq 0$, then 0 is a pole of order 3. If $c_2 = 0$, then the singularity at 0 becomes removable.

According to the above we have $a_{-1} = 0$, so $\operatorname{res}(f; 0) = 0$ for any such solution, and we have answered all questions with the exception of determining the recursion formula, which does not give sense any more.

Second method. *The standard method, i.e. the series method.* By inserting a formal Laurent series

$$f(z) = \sum a_n z^n$$

and its derivatives

$$f'(z) = \sum n a_n z^{n-1} \quad \text{and} \quad f''(z) = \sum n(n-1) a_n z^{n-2},$$

we get

$$\begin{aligned} 0 &= (z^2 - z) f''(z) + (5z - 4) f'(z) + 3 f(z) \\ &= \sum n(n-1) a_n z^n - \sum n(n-1) a_n z^{n-1} + \sum 5n a_n z^n - \sum 4n a_n z^{n-1} + \sum 3 a_n z^n \\ &= \sum \{n^2 - n + 5n + 3\} a_n z^n - \sum n(n+3) a_n z^{n-1} \\ &= \sum (n+1)(n+3) a_n z^n - \sum n(n+3) a_n z^{n-1} \\ &= \sum \{(n+1)(n+3) a_n - (n+1)(n+4) a_{n+1}\} z^n \\ &= \sum (n+1) \{(n+3) a_n - (n+4) a_{n+1}\} z^n. \end{aligned}$$

Then apply the *identity theorem* to get the *recursion formula*

$$(11) \quad (n+1) \{(n+3) a_n - (n+4) a_{n+1}\} = 0, \quad \text{for } n \in \mathbb{Z}.$$

The strategy is first to check the obvious zeros of the factors in (11).

If $n = -1$, then $n+1 = 0$. This implies that a_{-1} and a_0 are independent of each other, so *for the time being* they may be chosen arbitrarily.

Remark 3.1 We shall later see that we get a condition on a_{-1} , while a_0 is an arbitrary constant. However, this cannot yet be concluded. \diamond

If $n \neq -1$, the recursion formula is reduced to

$$(12) \quad (n+3) a_n = (n+4) a_{n+1}, \quad n \in \mathbb{Z} \setminus \{-1\}.$$

For $n = -4$, then $a_{-4} = 0$. Put $b_n = a_{-n}$, and derive from (12) that for $n \in \mathbb{N} \setminus \{1\}$,

$$(n-3) b_n = (n-4) b_{n-1}.$$

We get by recursion for $n \geq 4$,

$$(n-3) a_{-n} = (n-3) b_n = (n-4) b_{n-1} = \cdots = (4-4) b_{4-1} = 0,$$

so we conclude that $a_n = 0$ for $n \leq -4$. There is no restriction on $b_{4-1} = a_{-3}$, so this we also consider for the time being as an arbitrary constant.

If $n = -3$, then it follows from (12) that

$$a_{-2} = 0 \cdot a_{-3} = 0.$$

We conclude that a_{-3} is indeed an arbitrary constant, which can be chosen freely.

If $n = -2$, then

$$0 = (-2 + 3)a_{-2} = (-2 + 4)a_{-1},$$

so $a_{-1} = 0$. In particular,

$$\operatorname{res}(f; 0) = a_{-1} = 0$$

for every *convergent* series solution.

The case $n = -1$ has already been treated above.

If $n \in \mathbb{N}_0$, then it follows from (12) that

$$(n + 4)a_{n+1} = (n + 3)a_n = \cdots = (0 + 3)a_0 = 3a_0,$$

hence

$$a_n = \frac{3}{n + 3} a_0 \quad \text{for } n \in \mathbb{N}_0,$$

and we have found all coefficients.

Summing up, the formal Laurent series solutions are given by

$$(13) \quad f(z) = \frac{a_{-3}}{z^3} + a_0 \sum_{n=0}^{+\infty} \frac{3}{n + 3} z^n,$$

and it follows that the domain of convergence in general is $0 < |z| < 1$ for $a_{-3} \neq 0$ and $a_0 \neq 0$.

Please click the advert

**Student
Discounts**



+

**Student
Events**



+

**Money
Saving Advice**



=

**Happy
Days!**





SPECIAL CASES

If $a_{-3} = 0$ and $a_0 \neq 0$, then the domain of convergence is $|z| < 1$.

If $a_{-3} \neq 0$ and $a_0 = 0$, then the domain of convergence is $\mathbb{C} \setminus \{0\}$.

If $a_{-3} = a_0 = 0$, then $f(z) \equiv 0$ and the domain of convergence is \mathbb{C} .

Finally, we shall express the series $\sum_{n=0}^{+\infty} \frac{3}{n+3} z^n$ by elementary functions. If we put

$$g(z) = z^3 \sum_{n=0}^{+\infty} \frac{3}{n+3} z^n,$$

then we get for $|z| < 1$,

$$g(z) = 3 \sum_{n=0}^{+\infty} \frac{1}{n+3} z^{n+3} = 3 \sum_{n=3}^{+\infty} \frac{1}{n} z^n = 3 \sum_{n=1}^{+\infty} \frac{1}{n} z^n - 3z - \frac{3}{2} z^2 = -3 \operatorname{Log}(1-z) - 3z - \frac{3}{2} z^2,$$

thus

$$\begin{aligned} f(z) &= a_{-3} z^3 + a_0 \frac{g(z)}{z^3} \\ (14) \quad &= \frac{a_{-3}}{z^3} - 3a_0 \left\{ \frac{\operatorname{Log}(1-z)}{z^3} - \frac{1}{z^2} - \frac{3}{2} \frac{1}{z} \right\}, \quad 0 < |z| < 1, \end{aligned}$$

in agreement with the solution by the **first method** with $c_2 = a_{-3}$ and $c_1 = -3a_0$.

According to (13) (and not (14)) the Laurent series solutions which have a pole at $z = 0$, are given by $a_{-3} \neq 0$. The order is 3, and since (13) does not contain any term of the form $\frac{a_{-1}}{z}$ (i.e. $a_{-1} = 0$ for all solutions), we have

$$\operatorname{res}(f; 0) = a_{-1} = 0.$$

4 The residuum at ∞

Example 4.1 Find the residues at ∞ of the following functions,

$$(a) \frac{z^3}{z^4 - 1}, \quad (b) \left(z + \frac{2}{z}\right)^4, \quad (c) \frac{e^z}{z}.$$

(a) Since

$$f(z) = \frac{z^3}{z^4 - 1}$$

has a zero of first order at ∞ , we get

$$\operatorname{res}(f; \infty) = - \lim_{z \rightarrow \infty} z \cdot f(z) = - \lim_{z \rightarrow \infty} \frac{z^4}{z^4 - 1} = - \lim_{z \rightarrow \infty} \frac{1}{1 - \frac{1}{z^4}} = -1.$$

(b) It follows by the *binomial formula* that

$$\left(z + \frac{2}{z}\right)^4 = \frac{16}{z^4} + \frac{32}{z^2} + 24 + 8z^2 + z^4, \quad \text{for } z \in \mathbb{C} \setminus \{0\},$$

which we may consider of a degenerated Laurent series in a neighbourhood of ∞ . It follows from $a_{-1} = 0$ that

$$\operatorname{res}(f; \infty) = -a_{-1} = 0.$$

(c) Since

$$\operatorname{res}(f; 0) + \operatorname{res}(f; \infty) = 0,$$

it follows by a rearrangement that

$$\operatorname{res}(f; \infty) = -\operatorname{res}\left(\frac{e^z}{z}; 0\right) = -1.$$

ALTERNATIVELY,

$$\operatorname{res}(f; \infty) = -\operatorname{res}\left(\frac{1}{z^2} f\left(\frac{1}{z}\right); 0\right) = -\operatorname{res}\left(\frac{\exp\left(\frac{1}{z}\right)}{z}; 0\right) = -1,$$

because

$$\frac{1}{z} \exp \frac{1}{z} = \frac{1}{z} \sum_{n=0}^{+\infty} \frac{1}{n!} \frac{1}{z^n} = \frac{1}{z} + \frac{1}{z^2} + \frac{1}{2} \frac{1}{z^3} + \dots \quad \text{for } z \neq 0.$$

Example 4.2 Find the residues at ∞ of the following functions:

$$(a) \frac{1}{z(1-z^2)}, \quad (b) \frac{z^4}{(z^2+1)^2}, \quad (c) \frac{z^{2n}}{(1+z)^n}, \quad n \in \mathbb{N}.$$

(a) The function $f(z) = \frac{1}{z(1-z^2)}$ has a zero of order 3 at ∞ , so

$$\operatorname{res} \left(\frac{1}{z(1-z^2)}; \infty \right) = 0.$$

ALTERNATIVELY,

$$\operatorname{res} \left(\frac{1}{z(1-z^2)}; \infty \right) = -\operatorname{res} \left(\frac{1}{z^2} \cdot \frac{1}{\frac{1}{z} \left(1 - \frac{1}{z^2}\right)}; 0 \right) = -\operatorname{res} \left(\frac{z}{z^2-1}; 0 \right) = 0.$$

(b) The Laurent series expansion of the function

$$f(z) = \frac{z^4}{(z^2+1)^2}$$

only contains *even* powers of z , so $a_{-1} = 0$, and thus

$$\operatorname{res} \left(\frac{z^4}{(z^2+1)^2}; \infty \right) = 0.$$

(c) It follows by the rules of computation,

$$\begin{aligned} \operatorname{res} \left(\frac{z^{2n}}{(1+z)^n}; \infty \right) &= -\operatorname{res} \left(\frac{1}{z^2} \cdot \frac{\left(\frac{1}{z}\right)^{2n}}{\left(1 + \frac{1}{z}\right)^n}; 0 \right) = -\operatorname{res} \left(\frac{1}{z^{n+2}} \cdot \frac{1}{(z+1)^n}; 0 \right) \\ &= -\frac{1}{(n+1)!} \lim_{z \rightarrow 0} \frac{d^{n+1}}{dz^{n+1}} \left\{ \frac{1}{(z+1)^n} \right\} = -\frac{1}{(n+1)!} \lim_{z \rightarrow 0} \left\{ (-1)^{n+1} \cdot \frac{n(n+1) \cdots (n+n+1-1)}{(z+1)^{2n+1}} \right\} \\ &= (-1)^n \cdot \frac{1}{(n+1)!} \cdot \frac{(2n)!}{(n-1)!} = (-1)^n \binom{2n}{n-1}. \end{aligned}$$

ALTERNATIVELY, $z = -1$ is the only finite singularity, so

$$\operatorname{res}(f; -1) + \operatorname{res}(f; \infty) = 0,$$

and then by a rearrangement and RULE I for the residuum at a finite point,

$$\begin{aligned} \operatorname{res} \left(\frac{z^{2n}}{(1+z)^n}; \infty \right) &= -\operatorname{res} \left(\frac{z^{2n}}{(1+z)^n}; -1 \right) = -\frac{1}{(n-1)!} \lim_{z \rightarrow -1} \frac{d^{n-1}}{dz^{n-1}} (z^{2n}) \\ &= -\frac{1}{(n-1)!} \cdot 2n(2n-1) \cdots (n+2) \cdot (-1)^{n+1} \\ &= (-1)^n \cdot \frac{(2n)!}{(n-1)!(n+1)!} = (-1)^n \binom{2n}{n-1}. \end{aligned}$$

Example 4.3 Prove that $z = 0$ is an essential singularity of $\exp(z^{-2})$.
Then find

$$\operatorname{res}(\exp(z^{-2}); 0) \quad \text{and} \quad \operatorname{res}(\exp(z^{-2}); \infty).$$

It follows from

$$\exp\left(\frac{1}{z^2}\right) = \sum_{n=0}^{+\infty} \frac{1}{n!} \quad \text{for alle } z \in \mathbb{C} \setminus \{0\},$$

that

$$a_{-2n} = \frac{1}{n!} \neq 0, \quad \text{for } n \in \mathbb{N}_0,$$

proving that 0 is an essential singularity.

Since $a_{-1} = 0$, we have

$$\operatorname{res}\left(\exp\left(\frac{1}{z^2}\right); 0\right) = a_{-1} = 0.$$

Here $z = 0$ is the only finite singularity, so

$$\operatorname{res}\left(\exp\left(\frac{1}{z^2}\right); \infty\right) = -\operatorname{res}\left(\frac{1}{z^2} \exp(z^2); 0\right) = 0.$$

Please click the advert

WHAT'S MISSING IN THIS EQUATION?

You could be one of our future talents

MAERSK INTERNATIONAL TECHNOLOGY & SCIENCE PROGRAMME

Are you about to graduate as an **engineer** or **geoscientist**? Or have you already graduated?
If so, there may be an exciting future for you with A.P. Moller - Maersk.



MAERSK

www.maersk.com/mitas

ALTERNATIVELY we get by RULE IV,

$$\operatorname{res} \left(\exp \left(\frac{1}{z^2} \right); \infty \right) = -\operatorname{res} \left(\frac{1}{z^2} \exp(z^2); 0 \right) = 0,$$

because

$$\frac{1}{z^2} \exp(z^2) = \sum_{n=0}^{+\infty} \frac{1}{n!} z^{2n-2} \quad \text{for } z \neq 0,$$

and it follows that $a_{-1} = 0$.

Example 4.4 Find the residues at ∞ of the following functions

$$(a) \frac{1}{z^3 - z^5}, \quad (b) \frac{z^2 + 1}{z^3 + 1}, \quad (c) \left(z^2 + \frac{1}{z^2} \right) \sin z.$$

(a) We see that

$$\frac{1}{z^3 - z^5} = -\frac{1}{z^5} \cdot \frac{1}{1 - \frac{1}{z^2}}$$

has a zero of order 5 at ∞ , so

$$\operatorname{res} \left(\frac{1}{z^3 - z^5}; \infty \right) = 0.$$

(b) Since $\frac{z^2 + 1}{z^3 + 1}$ has a zero of first order at ∞ , we get

$$\operatorname{res} \left(\frac{z^2 + 1}{z^3 + 1}; \infty \right) = -\lim_{z \rightarrow \infty} z \cdot \frac{z^2 + 1}{z^3 + 1} = -1.$$

(c) It follows by a series expansion of $\sin z$ in the neighbourhood of ∞ that

$$\left(z^2 + \frac{1}{z^2} \right) \sin z = z^2 \sin z + \frac{1}{z} - \frac{1}{3!} z + \cdots, \quad z \neq 0.$$

The power series expansion of $z^2 \sin z$ is convergent in all of \mathbb{C} , so the Laurent series of $z^2 \sin z$ is equal to the power series, and it will not contribute to the negative indices. Therefore,

$$\operatorname{res} \left(\left(z^2 + \frac{1}{z^2} \right) \sin; \infty \right) = -a_{-1} = -1.$$

Example 4.5 Find the residues at ∞ of the following functions:

$$(a) \frac{z^2 + z + 1}{z^2(z-1)}, \quad (b) \frac{e^z}{z^2(z^2+9)}, \quad (c) \exp\left(z + \frac{1}{z}\right).$$

(a) Since $\frac{z^2 + z + 1}{z^2(z-1)}$ has a zero of first order at ∞ , it follows from RULE IV that

$$\operatorname{res}\left(\frac{z^2 + z + 1}{z^2(z-1)}; \infty\right) = -\lim_{z \rightarrow \infty} \frac{z(z^2 + z + 1)}{z^2(z-1)} = -\lim_{z \rightarrow \infty} \frac{1 + \frac{1}{z} + \frac{1}{z^2}}{1 - \frac{1}{z}} = -1.$$

(b) Since we have only a finite number of singularities in \mathbb{C} , and since the sum of the residues is zero, we get

$$\operatorname{res}(f; \infty) = -\operatorname{res}(f; 0) - \operatorname{res}(f; 3i) - \operatorname{res}(f; -3i).$$

Here $z = 0$ is a double pole, so

$$\operatorname{res}(f; 0) = \frac{1}{1!} \left[\frac{d}{dz} \left\{ \frac{e^z}{z^2 + 9} \right\} \right]_{z=0} = \left[\frac{e^z}{z^2 + 9} + z \{ \dots \} \right]_{z=0} = \frac{1}{9}.$$

Since $z = \pm 3i$ are simple poles, we get

$$\operatorname{res}(f; 3i) = \frac{e^{3i}}{(3i)^2(3i+3i)} = \frac{e^{3i}}{-27 \cdot 2i} = -\frac{1}{27} \cdot \frac{e^{3i}}{2i},$$

$$\operatorname{res}(f; -3i) = \frac{e^{-3i}}{(-3i)^2(-3i-3i)} = \frac{e^{-3i}}{27 \cdot 2i} = \frac{1}{27} \cdot \frac{e^{-3i}}{2i},$$

hence

$$\operatorname{res}(f; \infty) = -\frac{1}{9} - \frac{1}{27} \left\{ -\frac{e^{3i} - e^{-3i}}{2i} \right\} = -\frac{1}{9} + \frac{1}{27} \sin 3.$$

ALTERNATIVELY one may try RULE IV,

$$\operatorname{res}(f; \infty) = -\operatorname{res}\left(\frac{1}{z^2} f\left(\frac{1}{z}\right); 0\right) = -\operatorname{res}\left(\frac{z^2 \exp\left(\frac{1}{z}\right)}{9z^2 + 1}; 0\right),$$

which, however, does not look promising. It should be mentioned that it is *possible* to find the Laurent series from $z_0 = 0$; but the calculations are far more difficult than the argument above.

(c) We have for $z \neq 0$,

$$\exp\left(z + \frac{1}{z}\right) = \sum_{n=0}^{+\infty} \frac{1}{n!} \left(z + \frac{1}{z}\right)^n = \sum_{n=0}^{+\infty} \frac{1}{n!} \left\{ \sum_{j=0}^n \binom{n}{j} z^{2j-n} \right\},$$

so the coefficient a_{-1} corresponds to those terms for which $n = 2j + 1$, thus

$$\begin{aligned} \operatorname{res}(f; \infty) &= a_{-1} = - \sum_{j=0}^{+\infty} \frac{1}{(2j+1)!} \binom{2j+1}{j} = - \sum_{n=0}^{+\infty} \frac{(2n+1)!}{(2n+1)!n!(n+1)!} \\ &= - \sum_{n=0}^{+\infty} \frac{1}{n!(n+1)!}. \end{aligned}$$

By using the definition

$$J_m(z) = \sum_{n=0}^{+\infty} \frac{(-1)^n}{n!(m+n)!} \left(\frac{z}{2}\right)^{2n+n}, \quad m \in \mathbb{N}_0,$$

of the Bessel function of order m it follows that

$$\operatorname{res}(f; \infty) = - \sum_{n=0}^{+\infty} \frac{1}{n!(n+1)!} = i J_1(2i).$$

Example 4.6 Prove that

$$(a) \oint_{|z|=1} \frac{e^{\pi z}}{4z^2+1} dz = \pi i, \quad (b) \oint_{|z|=1} \frac{e^z}{z^3} dz = \pi i.$$

(a) The integrand has simple poles at $z_0 = \pm \frac{i}{2}$. Put

$$A(z) = e^{\pi z} \quad \text{and} \quad B(z) = 4z^2 + 1.$$

Then, using that $4z_0^2 = -1$, we get in each of the two cases of z_0 ,

$$\frac{A(z_0)}{B'(z_0)} = \frac{e^{\pi z_0}}{8z_0} = \frac{1}{4z_0^2} \cdot \frac{1}{2} \cdot z_0 e^{\pi z_0} = -\frac{1}{2} z_0 e^{\pi z_0}.$$

Hence,

$$\operatorname{res}\left(f; \frac{i}{2}\right) = -\frac{i}{2} \exp\left(i \frac{\pi}{2}\right) = -\frac{i}{4} \cdot i = \frac{1}{4},$$

$$\operatorname{res}\left(f; -\frac{i}{2}\right) = \frac{i}{4} \exp\left(-i \frac{\pi}{2}\right) = \frac{i}{4} (-i) = \frac{1}{4}.$$

Since both $\frac{i}{2}$ and $-\frac{i}{2}$ lie inside the circle $|z| = 1$, we finally get

$$\oint_{|z|=1} \frac{e^{\pi z}}{4z^2+1} dz = 2\pi i \left\{ \operatorname{res}\left(f; \frac{i}{2}\right) + \operatorname{res}\left(f; -\frac{i}{2}\right) \right\} = 2\pi i \left\{ \frac{1}{4} + \frac{1}{4} \right\} = \pi i.$$

(b) We have inside $|z| = 1$ a pole of order 3 at $z = 0$. It follows from

$$\frac{e^z}{z^3} = \sum_{n=0}^{+\infty} \frac{1}{n!} z^{n-3}, \quad z \in \mathbb{C} \setminus \{0\},$$

that

$$\operatorname{res}(f; 0) = a_{-1} = \frac{1}{2!} = \frac{1}{2},$$

hence

$$\oint_{|z|=1} \frac{e^z}{z^3} dz = 2\pi i \cdot \operatorname{res}(f; 0) = 2\pi i \cdot a_{-1} = \pi i.$$

Example 4.7 Compute $\oint_{|z|=2} \frac{z}{z^4 - 1} dz$.

This integral was previously computed in Example 3.4 by Rule II. We shall here show that it is much easier to use Rule IV instead, because

$$\oint_{|z|=2} \frac{z}{z^4 - 1} dz = - \oint_{|z|=2}^* \frac{z}{z^4 - 1} dz = -2\pi i \cdot \operatorname{res}\left(\frac{z}{z^4 - 1}; \infty\right) = 2\pi i \cdot \lim_{z \rightarrow \infty} \frac{z^2}{z^4 - 1} = 0,$$

where \oint^* denotes that we have changed the direction of the path of integration $\oint_C^* \cdots dz = - \oint_C \cdots dz$.

Please click the advert

CHALLENGE YOURSELF

WWW.STUDYINSWEDEN.SE

Today's job market values ambitious, innovative, perceptive team players. Swedish universities foster these qualities through a forward-thinking culture where you're close to the latest ideas and global trends.

Si.
Swedish Institute

Whatever your career goals may be, studying in Sweden will give you valuable skills and a competitive advantage for your future. www.studyinsweden.se

Example 4.8 Prove that

$$\oint_{|z|=1} \frac{e^z}{\left(z^2 + z - \frac{3}{4}\right)^2} dz = 0.$$

The poles of the integrand are given by

$$z = -\frac{1}{2} \pm \sqrt{\frac{1}{4} + \frac{3}{4}} = -\frac{1}{2} \pm 1,$$

thus

$$z_1 = \frac{1}{2} \quad \text{and} \quad z_2 = -\frac{3}{2}.$$

Only $z_1 = \frac{1}{2}$ lies inside the path of integration $|z| = 1$, and it is a pole of second order, so

$$\begin{aligned} \oint_{|z|=1} \frac{e^z}{\left(z^2 + z - \frac{3}{4}\right)^2} dz &= 2\pi i \cdot \operatorname{res} \left(\frac{e^z}{\left(z^2 + z - \frac{3}{4}\right)^2}; \frac{1}{2} \right) = \frac{2\pi i}{1!} \lim_{z \rightarrow \frac{1}{2}} \frac{d}{dz} \left\{ \frac{e^z}{\left(z + \frac{3}{2}\right)^2} \right\} \\ &= 2\pi i \lim_{z \rightarrow \frac{1}{2}} \left\{ \frac{e^z}{\left(z + \frac{3}{2}\right)^2} - 2 \frac{e^z}{\left(z + \frac{3}{2}\right)^3} \right\} = 2\pi i \sqrt{e} \cdot \left\{ \frac{1}{2^2} - \frac{2}{2^3} \right\} = 0. \end{aligned}$$

Example 4.9 Prove that

$$(a) \oint_{|z|=3} \frac{dz}{z(z-1)} = 0, \quad (b) \oint_{|z|=1} \frac{e^z + \sin z}{z} dz = 2\pi i.$$

(a) The poles $z = 0$ and $z = 1$ lie inside $|z| = 3$, so

$$\oint_{|z|=3} \frac{dz}{z(z-1)} = 2\pi i \left\{ \operatorname{res} \left(\frac{1}{z(z-1)}; 0 \right) + \operatorname{res} \left(\frac{1}{z(z-1)}; 1 \right) \right\} = 2\pi i \{-1 + 1\} = 0.$$

ALTERNATIVELY we have a zero of second order at ∞ , hence if we let \oint^* denote a closed path of integration of *negative* direction, then

$$\oint_{|z|=3} \frac{dz}{z(z-1)} = - \oint_{|z|=3}^* \frac{dz}{z(z-1)} = -2\pi i \cdot \operatorname{res} \left(\frac{1}{z(z-1)}; \infty \right) = 0.$$

(b) The simple pole $z = 0$ is the only singularity inside $|z| = 1$, so

$$\oint_{|z|=1} \frac{e^z + \sin z}{z} dz = 2\pi i \cdot \operatorname{res} \left(\frac{e^z + \sin z}{z}; 0 \right) = 2\pi i \{e^0 + \sin 0\} = 2\pi i.$$

Example 4.10 Prove that

$$(a) \oint_{|z|=2} \frac{dz}{(z-1)(z+3)} = \frac{\pi i}{2}, \quad (b) \oint_{|z|=4} \frac{\sin z}{(z-\pi)^3} dz = 0.$$

(a) Here, $z = 1$ is the only singularity inside $|z| = 2$, so

$$\oint_{|z|=2} \frac{dz}{(z-1)(z+3)} = 2\pi i \cdot \operatorname{res} \left(\frac{1}{(z-1)(z+3)}; 1 \right) = 2\pi i \cdot \frac{1}{4} = \frac{\pi i}{2}.$$

(b) Here, $z = \pi$ is the only singularity inside $|z| = 4$ (notice that $\pi < 4$), and since π is a pole of at most order 3 (it is actually only of order 2), it follows by RULE I that

$$\oint_{|z|=4} \frac{\sin z}{(z-\pi)^3} dz = 2\pi i \cdot \frac{1}{2!} \lim_{z \rightarrow \pi} \frac{d^2}{dz^2} \sin z = \pi i \lim_{z \rightarrow \pi} (-\sin z) = 0.$$

Example 4.11 Compute each of the following line integrals

$$(a) \oint_{|z|=2} \frac{z^3 - 3z + 1}{(z-i)^2} dz, \quad (b) \oint_{|z-1|=2} \frac{\cos z}{z^7} dz, \quad (c) \oint_{|z|=3} \frac{dz}{z^4 - 1}.$$

(a) Here, $z = i$ is a pole of at most second order inside $|z| = 2$, so

$$\oint_{|z|=2} \frac{z^3 - 3z + 1}{(z-i)^2} dz = \frac{2\pi i}{1!} \lim_{z \rightarrow i} \frac{d}{dz} (z^3 - 3z + 1) = 2\pi i \lim_{z \rightarrow i} (3z^2 - 3) = -12\pi i.$$

(b) Here, $z = 0$ is a pole of at most seventh order inside $|z-1| = 2$, so

$$\oint_{|z-1|=2} \frac{\cos z}{z^7} dz = \frac{2\pi i}{6!} \lim_{z \rightarrow 0} \frac{d^6}{dz^6} \cos z = \frac{2\pi i}{6!} \lim_{z \rightarrow 0} (-\cos z) = -\frac{2\pi i}{6!} = -\frac{\pi i}{360}.$$

ALTERNATIVELY, it follows by a series expansion for $z \neq 0$ that

$$\frac{\cos z}{z^7} = \frac{1}{z^7} \cdot \left\{ 1 - \frac{z^2}{2!} + \frac{z^4}{4!} - \frac{z^6}{6!} + \dots \right\} = \frac{1}{z^7} - \frac{1}{2} \frac{1}{z^5} + \frac{1}{24} \frac{1}{z^3} - \frac{1}{720} \frac{1}{z} + \dots,$$

and since $\operatorname{res}(f; 0) = a_{-1}$, we get

$$\oint_{|z-1|=2} \frac{\cos z}{z^7} dz = 2\pi i \cdot \operatorname{res}(f; 0) = -\frac{2\pi i}{720} = -\frac{\pi i}{360}.$$

(c) Each of the simple poles $z_0 = 1, i, -1, -i$, satisfies $z_0^4 = 1$, so

$$\operatorname{res} \left(\frac{1}{z^4 - 1}; z_0 \right) = \frac{1}{4z_0^3} = \frac{z_0}{4z_0^4} = \frac{z_0}{4}.$$

All poles lie inside $|z| = 4$, so

$$\oint_{|z|=3} \frac{dz}{z^4 - 1} = 2\pi i \sum_{j=1}^4 \operatorname{res}(f; z_j) = 2\pi i \left\{ \frac{1+i-1-i}{4} \right\} = 0.$$

ALTERNATIVELY, the integrand has a zero fourth order at ∞ , thus $\operatorname{res}(f; \infty) = 0$. Let \oint^* denote the closed line integral of *negative* direction. Since all finite poles lie inside $|z| = 3$, we get

$$\oint_{|z|=3} \frac{dz}{z^4 - 1} = -\oint_{|z|=3}^* \frac{dz}{z^4 - 1} = -2\pi i \cdot \operatorname{res}(f; \infty) = 0.$$

Example 4.12 Compute each of the following line integrals:

$$(a) \oint_{x^2+y^2=2x} \frac{dz}{z^4 + 1}, \quad (b) \oint_{|z-2|=\frac{1}{2}} \frac{dz}{(z-1)(z-2)^2}.$$

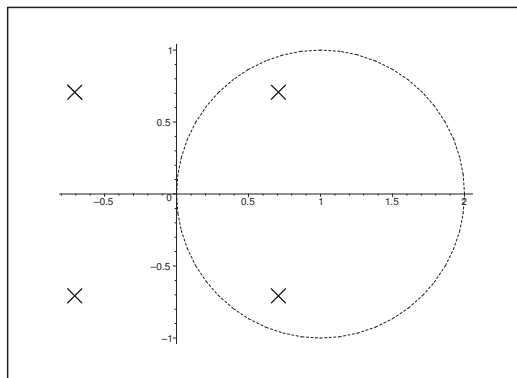

Figure 6: The path of integration and the four (simple) poles.

(a) Since the curve $x^2 + y^2 = 2x$, i.e.

$$(x-1)^2 + y^2 = 1,$$

surrounds the two simple poles $\exp\left(i\frac{\pi}{4}\right)$ and $\exp\left(-i\frac{\pi}{4}\right)$, and since the residues here are

$$\operatorname{res}\left(\frac{1}{z^4 + 1}; z_0\right) = \frac{1}{4z_0^3} = -\frac{z_0}{4} \quad \text{for } z_0^4 + 1 = 0,$$

we get

$$\oint_{x^2+y^2=2x} \frac{dz}{z^4 + 1} = 2\pi i \cdot \left(-\frac{1}{4}\right) \cdot \left\{ \exp\left(i\frac{\pi}{4}\right) + \exp\left(-i\frac{\pi}{4}\right) \right\} = -\pi i \cos\frac{\pi}{4} = -\frac{\pi i}{\sqrt{2}}.$$

Only the pole $z = 2$ lies inside the circle, so a direct computation gives

$$\begin{aligned} \oint_{|z-2|=\frac{1}{2}} \frac{dz}{(z-1)(z-2)^2} &= 2\pi i \cdot \operatorname{res} \left(\frac{1}{(z-1)(z-2)^2}; 2 \right) = \frac{2\pi i}{1!} \lim_{z \rightarrow 2} \frac{d}{dz} \left\{ \frac{1}{z-1} \right\} \\ &= 2\pi i \lim_{z \rightarrow 2} \left\{ -\frac{1}{(z-1)^2} \right\} = -2\pi i. \end{aligned}$$

ALTERNATIVELY we change the direction of integration, $\oint = -\oint^*$. We have a zero of order 3 at ∞ , so

$$\begin{aligned} \oint_{|z-2|=\frac{1}{2}} \frac{dz}{(z-1)(z-2)^2} &= -\oint_{|z-2|=\frac{1}{2}}^* \frac{dz}{(z-1)(z-2)^2} = -2\pi i \{ \operatorname{res}(f; 1) + \operatorname{res}(f; \infty) \} \\ &= -2\pi i \{ 1 + 0 \} = -2\pi i. \end{aligned}$$

Please click the advert

www.job.oticon.dk

oticon
PEOPLE FIRST

Download free books at BookBooN.com

Example 4.13 Compute each of the following line integrals:

$$(a) \oint_{|z|=2} \frac{dz}{(z-3)(z^5-1)}; \quad (b) \oint_{|z|=1} \frac{z^3}{2z^4+1} dz.$$

(a) The integrand has a zero of sixth order at ∞ , so when we change the direction of integration, $\oint = -\oint^*$, we get

$$\begin{aligned} \oint_{|z|=2} \frac{dz}{(z-3)(z^5-1)} &= -\oint_{|z|=2}^* \frac{dz}{(z-3)(z^5-1)} = -2\pi i \{\operatorname{res}(f; 3) + \operatorname{res}(f; \infty)\} \\ &= -\frac{2\pi i}{3^5-1} + 0 = -\frac{2\pi i}{242} = -\frac{\pi i}{121}. \end{aligned}$$

It is also possible to carry through an ALTERNATIVE solution, in which we compute the residues at the five simple poles z_0 , satisfying $z_0^5 = 1$:

$$\operatorname{res}\left(\frac{1}{(z-3)(z^5-1)}; z_0\right) = \frac{1}{z_0-3} \cdot \frac{1}{5z_0^4} = \frac{1}{5} \cdot \frac{z_0}{z_0-3} = \frac{1}{5} + \frac{3}{5} \cdot \frac{1}{z_0-3}.$$

We see that we get into some computational problems concerning the last term, because we for $z_0 = \exp\left(i\frac{2\pi}{5}\right)$ get the denominator

$$z_0 - 3 = \exp\left(i\frac{2\pi}{5}\right) - 3 = \left(\cos\frac{2\pi}{5} - 3\right) + i \sin\frac{2\pi}{5}.$$

(b) It follows from $\operatorname{res}(f; \infty) = -\frac{1}{2} = -a_{-1}$, that

$$\oint_{|z|=1} \frac{z^3}{2z^4+1} dz = -2\pi i \cdot \operatorname{res}(f; \infty) = \pi i.$$

ALTERNATIVELY,

$$\operatorname{res}\left(\frac{z^3}{2z^4+1}; z_0\right) = \lim_{z \rightarrow z_0} \frac{z^3}{8z^3} = \frac{1}{8}$$

for each of the four simple poles inside $|z| = 1$, thus

$$\oint_{|z|=1} \frac{z^3}{2z^4+1} dz = 2\pi i \cdot \frac{4}{8} = \pi i.$$

ALTERNATIVELY, the function $g(z) = 2z^4 + 1$ has the *winding number* 4 with respect to 0, and since $g'(z) = 8z^3$, we get

$$\oint_{|z|=1} \frac{z^3}{2z^4+1} dz = \frac{1}{8} \oint_{|z|=1} \frac{g'(z)}{g(z)} dz = \frac{4 \cdot 2\pi i}{8} = \pi i,$$

where the latter method assumes some knowledge of the *Principle of Argument*.

Example 4.14 Compute

$$\oint_{|z|=1} \frac{\cos(e^{-z})}{z^2} dz.$$

The double pole $z = 0$ is the only singularity inside $|z| = 1$, so

$$\begin{aligned} \oint_{|z|=1} \frac{\cos(e^{-z})}{z^2} dz &= 2\pi i \cdot \operatorname{res} \left(\frac{\cos(e^{-z})}{z^2}; 0 \right) = 2\pi i \cdot \frac{1}{1!} \lim_{z \rightarrow 0} \frac{d}{dz} \cos(e^{-z}) \\ &= 2\pi i \cdot \lim_{z \rightarrow 0} \{-\sin(e^{-z}) \cdot (-e^{-z})\} = 2\pi i \cdot \sin 1. \end{aligned}$$

Example 4.15 Find the residuum at $z = i$ for $\frac{1}{z^4 - 1}$.

Then compute the line integral

$$\oint_{|z-i|=\frac{1}{2}} \frac{1}{z^4 - 1} dz.$$

Since $z = i$ is a simple pole of $\frac{1}{z^4 - 1}$, we get by RULE II that

$$\operatorname{res} \left(\frac{1}{z^4 - 1}; i \right) = \lim_{z \rightarrow i} \frac{1}{4z^3} = \lim_{z \rightarrow i} \frac{z}{4z^4} = \frac{i}{4}.$$

The disc $|z - i| \leq \frac{1}{2}$ contains only the singular point $z = i$, so

$$\oint_{|z-i|=\frac{1}{2}} \frac{dz}{z^4 - 1} = 2\pi i \cdot \operatorname{res} \left(\frac{1}{z^4 - 1}; i \right) = 2\pi i \cdot \frac{i}{4} = -\frac{\pi}{2}.$$

Example 4.16 Compute

$$(a) \oint_{|z|=2} \frac{z}{z+1} dz, \quad (b) \oint_{|z|=2} \frac{z}{z^3+1} dz, \quad (c) \oint_{|z|=2} \frac{e^z}{z^2-1} dz.$$

(a) The singularity $z_0 = -1$ lies inside $|z| = 2$, so

$$\oint_{|z|=2} \frac{z}{z+1} dz = 2\pi i \cdot \operatorname{res} \left(\frac{z}{z+1}; -1 \right) = -2\pi i.$$

ALTERNATIVELY,

$$\begin{aligned} \oint_{|z|=2} \frac{z}{z+1} dz &= \oint_{|z|=2} \left\{ 1 - \frac{1}{z+1} \right\} dz = - \oint_{|z|=1} \frac{1}{z+1} dz \\ &= 2\pi i \cdot \operatorname{res} \left(\frac{1}{z+1}; \infty \right) = -2\pi i \lim_{z \rightarrow \infty} \frac{z}{z+1} = -2\pi i. \end{aligned}$$

(b) Since the integrand does not have any singularity in the set given by $|z| \geq 2$, and since $\frac{z}{z^3+1}$ has a zero of second order at ∞ , we get

$$\oint_{|z|=2} \frac{z}{z^3} dz = - \oint_{|z|=2}^* \frac{z}{z^3+1} dz = -2\pi i \cdot \operatorname{res} \left(\frac{z}{z^3+1}; \infty \right) = 0.$$

(c) The integrand has the two simple poles $z = \pm 1$ inside $|z| = 1$, thus

$$\begin{aligned} \oint_{|z|=2} \frac{e^z}{z^2-1} dz &= 2\pi i \left\{ \operatorname{res} \left(\frac{e^z}{z^2-1}; 1 \right) + \operatorname{res} \left(\frac{e^z}{z^2-1}; -1 \right) \right\} \\ &= 2\pi i \left\{ \frac{e^1}{2} - \frac{e^{-1}}{2} \right\} = 2\pi i \sinh 1. \end{aligned}$$

Please click the advert



CHALLENGE YOURSELF

WWW.STUDYINSWEDEN.SE

Today's job market values ambitious, innovative, perceptive team players. Swedish universities foster these qualities through a forward-thinking culture where you're close to the latest ideas and global trends.

Whatever your career goals may be, studying in Sweden will give you valuable skills and a competitive advantage for your future. www.studyinsweden.se

Si.
Swedish Institute

Download free books at BookBooN.com

Example 4.17 Compute the line integral

$$\oint_{|z|=5} \frac{z e^z}{1-z^2} dz.$$

It follows directly that

$$\begin{aligned} \oint_{|z|=5} \frac{z e^z}{1-z^2} dz &= 2\pi i \left\{ \operatorname{res} \left(-\frac{z e^z}{z^2-1}; 1 \right) + \operatorname{res} \left(-\frac{z e^z}{z^2-1}; -1 \right) \right\} \\ &= -2\pi i \left\{ \frac{1 \cdot e^1}{2} + \frac{(-1)e^{-1}}{-2} \right\} = -2\pi i \cosh 1. \end{aligned}$$

Example 4.18 Compute

$$(a) \oint_{|z-1|=2} \frac{1}{z^4+1} dz, \quad (b) \oint_{|z|=2} \frac{dz}{z^2(z+1)}.$$

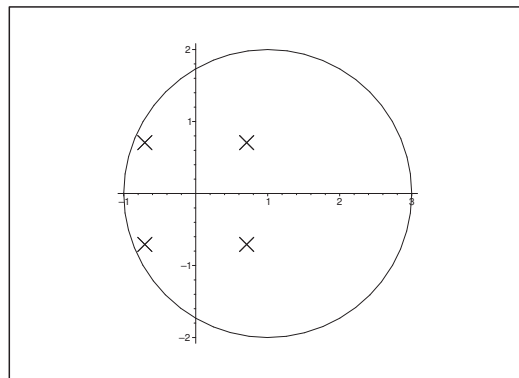

Figure 7: The four simple poles all lie inside $|z-1|=2$.

(a) It follows from

$$\{z \in \mathbb{C} \mid |z| \leq 1\} \subseteq \{z \in \mathbb{C} \mid |z-1| \leq 2\},$$

that all singularities lie inside the closed path of integration $|z-1|=2$. We have a zero of fourth order at ∞ , so we get by changing the direction of the path of integration,

$$\oint_{|z-1|=2} \frac{dz}{z^4+1} = - \oint_{|z-1|=2}^* \frac{dz}{z^4+1} = -2\pi i \cdot \operatorname{res} \left(\frac{1}{z^4+1}; \infty \right) = 0.$$

(b) Every pole lies inside $|z|=2$, and we have a zero of order 3 at ∞ . Therefore,

$$\oint_{|z|=2} \frac{dz}{z^2(z+1)} = - \oint_{|z|=2}^* \frac{dz}{z^2(z+1)} = -2\pi i \cdot \operatorname{res} \left(\frac{1}{z^2(z+1)}; \infty \right) = 0.$$

Example 4.19 Compute

$$(a) \oint_{|z|=2} \frac{\sin z}{(z-1)^2(z^2+9)} dz, \quad (b) \oint_{|z|=2} \frac{z^7}{(z^4+1)^2}, \quad (c) \oint_{|z|=1} \frac{e^z}{z^3} dz.$$

(a) We have inside $|z| = 2$ only one singularity $z = 1$ (a double pole). It follows by the *residuum theorem* that

$$\begin{aligned} \oint_{|z|=2} \frac{\sin z}{(z-1)^2(z^2+9)} dz &= 2\pi i \cdot \operatorname{res} \left(\frac{\sin z}{(z-1)^2(z^2+9)}; 1 \right) = \frac{2\pi i}{1!} \lim_{z \rightarrow 1} \frac{d}{dz} \left\{ \frac{\sin z}{z^2+9} \right\} \\ &= 2\pi i \lim_{z \rightarrow 1} \left\{ \frac{\cos z}{z^2+9} - \frac{2z \sin z}{(z^2+9)^2} \right\} = 2\pi i \left\{ \frac{\cos 1}{10} - \frac{2 \sin 1}{100} \right\} \\ &= \frac{5 \cos 1 - \sin 1}{25} \cdot \pi i. \end{aligned}$$

(b) We have four double poles lying inside the curve $|z| = 1$, and no singularity outside this curve. Since we have a zero of first order at ∞ , it follows by RULE IV that

$$\begin{aligned} \oint_{|z|=2} \frac{z^7}{(z^4+1)^2} dz &= - \oint_{|z|=2}^* \frac{z^7}{(z^4+1)^2} dz = -2\pi i \cdot \operatorname{res} \left(\frac{z^7}{(z^4+1)^2}; \infty \right) \\ &= -2\pi i \left\{ - \lim_{z \rightarrow \infty} z \cdot \frac{z^7}{(z^4+1)^2} \right\} = 2\pi i \cdot \lim_{z \rightarrow \infty} \left\{ \frac{1}{\left(1 + \frac{1}{z^4}\right)^2} \right\} = 2\pi i. \end{aligned}$$

ALTERNATIVELY it is possible here to apply RULE III, i.e.

$$\operatorname{res}(f; z_0) = \frac{6A'B'' - 2AB'''}{3(B'')^2} = \frac{2A'}{B''} - \frac{2}{3} \cdot \frac{AB'''}{(B'')^2},$$

where

$$A(z) = z^7 \quad \text{and} \quad B(z) = (z^4+1)^2 = z^8 + 2z^4 + 1.$$

Finally, $z_0^4 = -1$, so

$$A = z_0^7 = \frac{1}{z_0}, \quad \text{and} \quad A' = 7z_0^6 = -7z_0^2,$$

$$B' = 8(z_0^7 + z_0^3), \quad B'' = 8(7z_0^6 + 3z_0^2), \quad B''' = 8(42z_0^5 + 6z_0),$$

thus

$$B'' = -32z_0^2 \quad \text{and} \quad B''' = -8 \cdot 36z_0.$$

We have for each of the four poles z_0 that

$$\operatorname{res}(f; z_0) = \frac{2(-7z_0^2)}{-32z_0^2} - \frac{2}{3} \cdot \frac{(-8 \cdot 36)}{32^2 \cdot z_0^4} = \frac{7}{16} - \frac{16 \cdot 3^2 \cdot 4}{3 \cdot 16^2 \cdot 4} = \frac{1}{4}.$$

The sum of the four residues is 1, so

$$\oint_{|z|=2} \frac{z^7}{(z^4+1)^2} dz = 2\pi i.$$

(c) It follows from

$$\frac{e^z}{z^3} = \frac{1}{z^3} \left\{ 1 + \frac{z}{1!} + \frac{z^2}{2!} + \cdots \right\},$$

that

$$a_{-1} = \frac{1}{2!} = \frac{1}{2},$$

hence

$$\oint_{|z|=1} \frac{e^z}{z^3} dz = 2\pi i \cdot \text{res} \left(\frac{e^z}{z^3}; 0 \right) = 2\pi i \cdot a_{-1} = \pi i.$$

ALTERNATIVELY, by RULE I,

$$\oint_{|z|=1} \frac{e^z}{z^3} dz = 2\pi i \cdot \text{res} \left(\frac{e^z}{z^3}; 0 \right) = 2\pi i \cdot \frac{1}{2!} \lim_{z \rightarrow 0} \frac{d^2}{dz^2} e^z = \pi.$$

Example 4.20 Compute

$$(a) \oint_{|z|=2} \frac{4z^3 + 2z}{z^4 + 2z^2 + 1} dz, \quad (b) \oint_{|z|=2} \frac{dz}{(z-1)^3(z-7)}.$$

(a) We see from

$$z^4 + 2z^2 + 1 = (z^2 + 1)^2 = (z-i)^2(z+i)^2,$$

that we have two double poles $z_0 = \pm i$. In particular, $z_0^2 = -1$ and

$$\frac{(z-z_0)^2}{z^4 + 2z^2 + 1} = \frac{1}{(z+z_0)^2}.$$

Thus by RULE I,

$$\begin{aligned} \text{res} \left(\frac{4z^3 + 2z}{z^4 + 2z^2 + 1}; z_0 \right) &= \frac{1}{1!} \lim_{z \rightarrow z_0} \frac{d}{dz} \left\{ \frac{4z^3 + 2z}{(z+z_0)^2} \right\} = \lim_{z \rightarrow z_0} \left\{ \frac{12z^2 + 2}{(z+z_0)^2} - 2 \frac{4z^3 + 2z}{(z+z_0)^2} \right\} \\ &= \frac{12z_0^2 + 2}{(2z_0)^2} - 2 \cdot \frac{4z_0^3 + 2z_0}{(2z_0)^3} = \frac{-12 + 2}{-4} - \frac{4z_0(2z_0^2 + 1)}{2z_0 \cdot 4z_0^2} \\ &= \frac{5}{2} + \frac{1}{2}(-2 + 1) = 2, \end{aligned}$$

and we conclude from the residuum theorem that

$$\oint_{|z|=2} \frac{4z^3 + 2z}{z^4 + 2z^2 + 1} dz = 2\pi i \{ \text{res}(f; i) + \text{res}(f; -i) \} = 2\pi i \{ 2 + 2 \} = 8\pi i.$$

ALTERNATIVELY we have a zero of first order at ∞ , and no further singularities outside $|z| = 2$, hence

$$\begin{aligned} \oint_{|z|=2} \frac{4z^3 + 2z}{z^4 + 2z^2 - 1} dz &= - \oint_{|z|=1}^* \frac{4z^3 + 2z}{z^4 + 2z^2 + 1} dz = -2\pi i \cdot \text{res}(f; \infty) \\ &= -2\pi i \lim_{z \rightarrow \infty} \left\{ -z \cdot \frac{4z^3 + 2z}{z^4 + 2z^2 + 1} \right\} = -2\pi i \cdot (-4) = 8\pi i. \end{aligned}$$

(b) The only pole inside $|z| = 2$ is the triple pole $z = 1$, so we find

$$\begin{aligned} \oint_{|z|=2} \frac{dz}{(z-1)^3(z-7)} &= 2\pi i \text{res} \left(\frac{1}{(z-1)^3(z-7)}; 1 \right) = 2\pi i \cdot \frac{1}{2!} \lim_{z \rightarrow 1} \frac{d^2}{dz^2} \left\{ \frac{1}{z-7} \right\} \\ &= \pi i \lim_{z \rightarrow 1} \left\{ -\frac{1}{(z-7)^2} \right\} = \pi i \cdot \lim_{z \rightarrow 1} \frac{2}{(z-7)^3} = \pi i \cdot \frac{2}{(-6)^3} = -\frac{\pi i}{108}. \end{aligned}$$

ALTERNATIVELY,

$$\begin{aligned} \oint_{|z|=7} \frac{dz}{(z-1)^3(z-7)} &= - \oint_{|z|=2}^* \frac{dz}{(z-1)^3(z-7)} = -2\pi i \{ \text{res}(f; 7) + \text{res}(f; \infty) \} \\ &= -2\pi i \left\{ \lim_{z \rightarrow 7} \frac{1}{(z-1)^3} + 0 \right\} = -\frac{2\pi i}{6^3} = -\frac{\pi i}{108}, \end{aligned}$$

because the integrand has a zero of order 4 at ∞ (RULE IV).

Please click the advert

Turning a challenge into a learning curve. Just another day at the office for a high performer.

Accenture Boot Camp – your toughest test yet

Choose Accenture for a career where the variety of opportunities and challenges allows you to make a difference every day. A place where you can develop your potential and grow professionally, working alongside talented colleagues. The only place where you can learn from our unrivalled experience, while helping our global clients achieve high performance. If this is your idea of a typical working day, then Accenture is the place to be.

It all starts at Boot Camp. It's 48 hours that will stimulate your mind and enhance your career prospects. You'll spend time with other students, top Accenture Consultants and special guests. An inspirational two days

packed with intellectual challenges and activities designed to let you discover what it really means to be a high performer in business. We can't tell you everything about Boot Camp, but expect a fast-paced, exhilarating

and intense learning experience. It could be your toughest test yet, which is exactly what will make it your biggest opportunity.

Find out more and apply online.

Visit accenture.com/bootcamp

• Consulting • Technology • Outsourcing

accenture
High performance. Delivered.

Example 4.21 *Compute*

$$(a) \oint_{|z|=1} \frac{e^z}{z^5} dz, \quad (b) \oint_{|z|=2} \frac{dz}{z^2(z-3)}, \quad (c) \oint_{|z|=2} \frac{\sin z}{\left(z - \frac{\pi}{2}\right)^2} dz.$$

(a) We have only the pole $z = 1$ of order 5 lying inside the curve $|z| = 1$. Hence by RULE I,

$$\oint_{|z|=1} \frac{e^z}{z^5} dz = 2\pi i \cdot \frac{1}{4!} \lim_{z \rightarrow 1} \frac{d^4}{dz^4} e^z = \frac{2\pi i}{4!} = \frac{\pi i}{12}.$$

ALTERNATIVELY we may find a_{-1} in the Laurent series expansion

$$\frac{e^z}{z^5} = \frac{1}{z^5} \left\{ 1 + z + \frac{z^2}{2!} + \frac{z^3}{3!} + \frac{z^4}{4!} + \dots \right\},$$

hence

$$a_{-1} = \frac{1}{4!} = \frac{1}{24},$$

and thus

$$\oint_{|z|=1} \frac{e^z}{z^5} dz = 2\pi i \cdot \frac{1}{24} = \frac{\pi i}{12}.$$

(b) We have only the double pole $z = 0$ lying inside the closed curve $|z| = 2$. Then by RULE I,

$$\oint_{|z|=2} \frac{dz}{z^2(z-3)} = 2\pi i \cdot \frac{1}{1!} \cdot \lim_{z \rightarrow 0} \frac{d}{dz} \left\{ \frac{1}{z-3} \right\} = 2\pi i \lim_{z \rightarrow 0} \left\{ -\frac{1}{(z-3)^2} \right\} = -\frac{2\pi i}{9}.$$

ALTERNATIVELY, $z = 3$ is a simple pole *outside* $|z| = 2$. Furthermore, we have a zero of order 3 at ∞ , so we get by changing the direction of the path of integration, $\oint = -\oint^*$, that

$$\begin{aligned} \oint_{|z|=2} \frac{dz}{z^2(z-3)} &= -\oint_{|z|=2}^* \frac{dz}{z^2(z-3)} = -2\pi i \left\{ \operatorname{res} \left(\frac{1}{z^2(z-3)}; 3 \right) + \operatorname{res} \left(\frac{1}{z^2(z-3)}; \infty \right) \right\} \\ &= -2\pi i \left\{ \frac{1}{9} + 0 \right\} = -\frac{2\pi i}{9}. \end{aligned}$$

(c) It follows from $\left| \frac{\pi}{2} \right| < 2$ and $\sin \frac{\pi}{2} = 1$ that $z = \frac{\pi}{2}$ is a double pole lying inside $|z| = 2$. This is the only singularity in \mathbb{C} , so we get by the residuum theorem that

$$\oint_{|z|=2} \frac{\sin z}{\left(z - \frac{\pi}{2}\right)^2} dz = 2\pi i \cdot \frac{1}{1!} \lim_{z \rightarrow \frac{\pi}{2}} \frac{d}{dz} \sin z = 2\pi i \lim_{z \rightarrow \frac{\pi}{2}} \cos z = 0.$$

ALTERNATIVELY we expand $\sin z$ as a power series from $z_0 = \frac{\pi}{2}$, i.e.

$$\sin z = 1 + 0 \cdot \left(z - \frac{\pi}{2}\right) - \frac{1}{2} \left(z - \frac{\pi}{2}\right)^2 + \dots,$$

hence

$$\frac{\sin z}{\left(z - \frac{\pi}{2}\right)^2} = \frac{1}{\left(z - \frac{\pi}{2}\right)^2} + \frac{0}{z - \frac{\pi}{2}} + \dots,$$

so $a_{-1} = 0$, and we get

$$\oint_{|z|=2} \frac{\sin z}{\left(z - \frac{\pi}{2}\right)^2} dz = 2\pi \cdot a_{-1} = 0.$$

Example 4.22 Let C denote the boundary of the square of the corners $\pm 2 \pm 2i$. Compute

$$(a) \oint_C \frac{e^{-z}}{z - i\frac{\pi}{2}} dz, \quad (b) \oint_C \frac{\cos z}{z(z^2 + 8)} dz, \quad (c) \oint_C \frac{z}{2z + 1} dz.$$

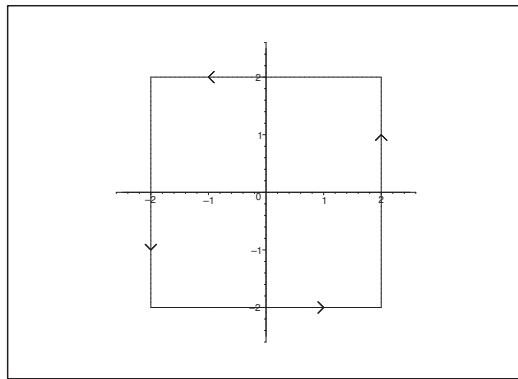

Figure 8: The curve C .

(a) The integrand

$$\frac{e^{-z}}{z - i\frac{\pi}{2}}$$

has inside C only the simple pole at $z = i\frac{\pi}{2}$. Therefore, by RULE I,

$$\oint_C \frac{e^{-z}}{z - i\frac{\pi}{2}} dz = 2\pi i \cdot \operatorname{res} \left(\frac{e^{-z}}{z - i\frac{\pi}{2}}; i\frac{\pi}{2} \right) = 2\pi i \exp \left(-i\frac{\pi}{2} \right) = 2\pi.$$

(b) The integrand

$$\frac{\cos z}{z(z^2 + 8)}$$

has the simple poles $z = 0$ and $z = \pm i 2\sqrt{2}$. Only $z = 0$ lies inside C , so it follows by the residuum theorem and RULE I that

$$\oint_C \frac{\cos z}{z(z^2 + 8)} dz = 2\pi i \cdot \operatorname{res} \left(\frac{\cos z}{z(z^2 + 8)}; 0 \right) = 2\pi i \lim_{z \rightarrow 0} \frac{\cos z}{z^2 + 8} = \frac{\pi i}{4}.$$

(c) The integrand $\frac{z}{2z+1}$ has a simple pole at $z = -\frac{1}{2}$ inside C . Hence,

$$\oint_C \frac{z}{z+1} dz = 2\pi i \cdot \operatorname{res} \left(\frac{z}{z+1}; -\frac{1}{2} \right) = 2\pi \lim_{z \rightarrow -\frac{1}{2}} \frac{\left(z + \frac{1}{2}\right) z}{2z+1} = 2\pi i \lim_{z \rightarrow -\frac{1}{2}} \frac{z}{2} = -\frac{2\pi i}{4} = -\frac{\pi i}{2}.$$

Example 4.23 Compute the following line integrals:

$$(a) \oint_{|z|=\frac{1}{2}} \frac{(1-z^4)e^{2z}}{z^3} dz, \quad (b) \oint_{|z|=1} \frac{\sinh z}{\sin z} dz.$$

(a) Here $z e^{2z}$ is analytic in all of \mathbb{C} , so it follows by a direct computation and reduction, and the residuum theorem that

$$\oint_{|z|=\frac{1}{2}} \frac{(1-z^4)e^{2z}}{z^3} dz = \oint_{|z|=\frac{1}{2}} \frac{e^{2z}}{z^3} dz - \oint_{|z|=\frac{1}{2}} z e^{2z} dz = \oint_{|z|=\frac{1}{2}} \frac{e^{2z}}{z^3} dz + 0 = \frac{2\pi i}{2!} \lim_{z \rightarrow 0} \frac{d^2}{dz^2} e^{2z} = 4\pi i.$$

(b) The singularity at $z = 0$ is removable, so $\frac{\sinh z}{\sin z}$, extended by the value 1 at $z = 0$, is analytic everywhere inside and on the closed curve $|z| = 1$. We conclude from Cauchy's integral theorem that

$$\oint_{|z|=1} \frac{\sinh z}{\sin z} dz = 0.$$

Example 4.24 Compute each of the following line integrals:

$$(a) \frac{1}{2\pi i} \oint_{|z|=1} \sin\left(\frac{1}{z}\right) dz, \quad (b) \frac{1}{2\pi i} \oint_{|z|=1} \sin^2\left(\frac{1}{z}\right) dz.$$

(a) We see from

$$\sin \frac{1}{z} = \frac{1}{z} - \frac{1}{3!z^3} + \dots$$

for $z \neq 0$, that $a_{-1} = 1$, hence

$$\frac{1}{2\pi i} \oint_{|z|=1} \sin\left(\frac{1}{z}\right) dz = \operatorname{res} \left(\sin\left(\frac{1}{z}\right); 0 \right) = a_{-1} = 1.$$

(b) It follows from

$$\sin^2\left(\frac{1}{z}\right) = \frac{1}{2} \left\{ 1 - \cos\left(\frac{2}{z}\right) \right\} = \frac{1}{2} - \frac{1}{2} \left\{ 1 - \frac{1}{2!} \left(\frac{2}{z}\right)^2 + \dots \right\} = \frac{1}{z^2} - \dots,$$

that $a_{-1} = 0$, and hence by the residuum theorem,

$$\frac{1}{2\pi i} \oint_{|z|=1} \sin^2\left(\frac{1}{z}\right) dz = 0.$$

Please click the advert



it's an **interesting** world

Get under the skin of it.

Graduate opportunities
Cheltenham | £24,945 + benefits

One of the UK's intelligence services, GCHQ's role is two-fold: to gather and analyse intelligence which helps shape Britain's response to global events, and, to provide technical advice for the protection of Government communication and information systems. In doing so, our specialists – in IT, internet, engineering, languages, information assurance, mathematics and intelligence – get well beneath the surface of global affairs. If you thought the world was an interesting place, you really ought to explore our world of work.

www.careersinbritishintelligence.co.uk

Applicants must be British citizens. GCHQ values diversity and welcomes applicants from all sections of the community. We want our workforce to reflect the diversity of our work.



Example 4.25 *Given*

$$f(z) = \frac{2\sqrt{2} \cdot z^4 + z^3 - 2z + \sqrt{2}}{z(z - \sqrt{2})(\sqrt{2} \cdot z - 1)^3}.$$

Compute the complex line integral

$$\oint_{|z|=1} f(z) dz,$$

where the path of integration is taken in the positive direction, by changing this direction of the path of integration.

The function $f(z)$ is a rational function of the simple pole $z = 0$ and the unpleasant triple pole $z = \frac{1}{\sqrt{2}}$ inside $|z| = 1$, and the simple pole $z = \sqrt{2}$ outside the circle. If we change the direction of the path of integration and then apply the residue theorem, then

$$\begin{aligned} \oint_{|z|=1} f(z) dz &= - \oint_{|z|=1}^* f(z) dz = -2\pi i \{ \text{res}(f; \sqrt{2}) + \text{res}(f; \infty) \} \\ &= -2\pi i \left[\frac{2\sqrt{2} \cdot z^4 + z^3 - 2z + \sqrt{2}}{z \cdot (\sqrt{2} \cdot z - 1)^3} \right]_{z=\sqrt{2}} - \left\{ - \lim_{z \rightarrow \infty} z \cdot f(z) \right\} \cdot 2\pi i \\ &= -2\pi i \left\{ \frac{8\sqrt{2} + 2\sqrt{2} - 2\sqrt{2} + \sqrt{2}}{\sqrt{2} \cdot (2 - 1)^3} \right\} + 2\pi i \cdot \frac{2\sqrt{2}}{(\sqrt{2})^3} \\ &= -18\pi i + 2\pi i = -16\pi i. \end{aligned}$$

ALTERNATIVELY we compute $\text{res}(f; 0)$ and $\text{res}\left(f; \frac{1}{\sqrt{2}}\right)$. We note that

$$(\sqrt{2} \cdot z - 1)^3 = (\sqrt{2})^3 \cdot \left(z - \frac{1}{\sqrt{2}}\right)^3.$$

First we get for $z = 0$ that

$$\text{res}(f; 0) = \frac{\sqrt{2}}{(-\sqrt{2})(-1)^3} = 1.$$

Then we use RULE I to compute the residuum at the triple pole $z = \frac{1}{\sqrt{2}}$:

$$\begin{aligned} \text{res}\left(f; \frac{1}{\sqrt{2}}\right) &= \frac{1}{2!} \lim_{z \rightarrow \frac{1}{\sqrt{2}}} \frac{d^2}{dz^2} \left\{ \frac{2\sqrt{2} \cdot z^4 + z^3 - 2z + \sqrt{2}}{z(z - \sqrt{2})(\sqrt{2})^3} \right\} \\ &= \frac{1}{2} \cdot \frac{1}{(\sqrt{2})^3} \lim_{z \rightarrow \frac{1}{\sqrt{2}}} \frac{d^2}{dz^2} \left\{ \frac{2\sqrt{2} z^4 + z^3 - 2z + \sqrt{2}}{z(z - \sqrt{2})} \right\}. \end{aligned}$$

Put

$$h(z) = \frac{2\sqrt{2} \cdot z^4 + z^3 - 2z + \sqrt{2}}{z(z - \sqrt{2})},$$

and then perform a division of polynomials and a decomposition to get

$$h(z) = \frac{2\sqrt{2} \cdot z^4 + z^3 - 2z + \sqrt{2}}{z(z - \sqrt{2})} = 2\sqrt{2} \cdot z^2 + 5z + 5\sqrt{2} - \frac{1}{z} + \frac{9}{z - \sqrt{2}}.$$

Clearly, it is much easier to differentiate the latter expression of $h(z)$ than the former one. We obtain

$$h''(z) = 4\sqrt{2} - \frac{2}{z^3} + \frac{18}{(z - \sqrt{2})^3},$$

hence by insertion

$$\begin{aligned} \operatorname{res}\left(f; \frac{1}{\sqrt{2}}\right) &= \frac{1}{2!(\sqrt{2})^3} h''\left(\frac{1}{\sqrt{2}}\right) = \frac{1}{2(\sqrt{2})^3} \left\{ 4\sqrt{2} - 2(\sqrt{2})^3 + \frac{18}{\left(\frac{1}{\sqrt{2}} - \sqrt{2}\right)^3} \right\} \\ &= \frac{1}{2(\sqrt{2})^3} \left\{ 0 + \frac{18}{\left(\frac{1-2}{\sqrt{2}}\right)^3} \right\} = -9. \end{aligned}$$

Please click the advert



Brain power

By 2020, wind could provide one-tenth of our planet's electricity needs. Already today, SKF's innovative know-how is crucial to running a large proportion of the world's wind turbines.

Up to 25 % of the generating costs relate to maintenance. These can be reduced dramatically thanks to our systems for on-line condition monitoring and automatic lubrication. We help make it more economical to create cleaner, cheaper energy out of thin air.

By sharing our experience, expertise, and creativity, industries can boost performance beyond expectations. Therefore we need the best employees who can meet this challenge!

The Power of Knowledge Engineering

Plug into The Power of Knowledge Engineering.
Visit us at www.skf.com/knowledge

SKF

Finally, we get

$$\oint_{|z|=1} f(z) dz = 2\pi i \left\{ \operatorname{res}(f; 0) + \operatorname{res}\left(f; \frac{1}{\sqrt{2}}\right) \right\} = 2\pi i \cdot \{1 - 9\} = -16\pi i.$$

Example 4.26 Given the differential equation

$$(15) \quad z^4 f''(z) + (2z^3 + z) f'(z) = f(z).$$

Assuming that

$$f(z) = \sum_{n=-\infty}^{+\infty} a_n z^n$$

is a convergent Laurent series solution in a domain of the form $\{z \in \mathbb{C} \mid r < |z| < R\}$ satisfying (15), we shall find a recursion formula for a_n with polynomial coefficients, and also prove that $a_n = 0$, when $n \in \mathbb{N}$.

Then find all Laurent series solution of (15).

HINT: The general solution cannot be expressed by elementary functions.

Denote by $f_0(z)$ the Laurent series solution of (15), which also satisfies

$$f_0(1) = \sqrt{e}, \quad \operatorname{res}(f_0; \infty) = 0.$$

Express $f_0(z)$ by elementary functions.

Here there are many possibilities of solution. We shall go through some of them:

- 1) The power series method (the standard method),
- 2) Transformation of the differential equation,
- 3) Inspection,
- 4) Transformation, follows by an inspection.

First method. The power series method (the standard method). Assume that the Laurent series

$$f(z) = \sum_{n=-\infty}^{+\infty} a_n z^n$$

is a solution of (15) in the annulus

$$\Omega = \{z \in \mathbb{C} \mid r < |z| < R\}.$$

Then we have in Ω ,

$$f'(z) = \sum_{n=-\infty}^{+\infty} n a_n z^{n-1} \quad \text{og} \quad f''(z) = \sum_{n=-\infty}^{+\infty} n(n-1) a_n z^{n-2}.$$

When we put these series into (15), we get by reduction,

$$\begin{aligned}
 0 &= z^4 f''(z) + 2z^3 f'(z) + z f'(z) - f(z) \\
 &= \sum n(n-1)a_n z^{n+2} + \sum 2n a_n z^{n+2} + \sum n a_n z^n - \sum a_n z^n \\
 (16) &= \sum n(n+1)a_n z^{n+2} + \sum (n-1)a_n z^n \\
 &= \sum (n-2)(n-1)a_{n-2} z^n + \sum (n-1)a_n z^n \\
 &= \sum (n-1) \{(n-2)a_{n-2} + a_n\} z^n.
 \end{aligned}$$

From (16) also follows that

$$\begin{aligned}
 0 &= \sum n(n+1)a_n z^{n+2} + \sum (n-1)a_n z^n \\
 &= \sum n(n+1)a_n z^{n+2} + \sum (n+1)a_{n+2} z^{n+2} \\
 &= \sum (n+1) \{n a_n + a_{n+2}\} z^{n+2}.
 \end{aligned}$$

We have now the following two “variants” of the recursion formula, which shall both be fulfilled for all $n \in \mathbb{Z}$:

$$(n-1) \{(n-2)a_{n-2} + a_n\} = 0, \quad (n+1) \{n a_n + a_{n+2}\} = 0.$$

The treatment of each of the two recursion formulæ is in principle the same, so we shall only solve one of them, namely,

$$(n-1) \{(n-2)a_{n-2} + a_n\} = 0, \quad n \in \mathbb{Z}.$$

If $n = 1$, then the left hand side is identically zero, so a_{-1} and a_1 are independent of each other.

If $n \neq 1$, then the recursion formula is reduced to

$$(n-2)a_{n-2} + a_n = 0, \quad n \in \mathbb{Z} \setminus \{1\}.$$

If $n = 2$, then $a_2 = 0$, and since we have a leap of 2 in the indices in the recursion formula, it follows that

$$a_{2n} = 0 \quad \text{for } n \in \mathbb{N}.$$

If $n = 2p + 1$, $p \in \mathbb{N}$, is odd, it follows by recursion that

$$a_{2p+1} = -(2p-1)a_{2p-1} = \cdots (-1)^p (2p-1)(2p-3) \cdots 3 \cdot 1 \cdot a_1,$$

and since a_1 is seemingly arbitrary, we *cannot* immediately conclude that $a_{2p+1} = 0$, $p \in \mathbb{N}_0$. The point is that we shall only find the *convergent* series solutions. Assume that $a_1 \neq 0$. Then it follows from the above that $a_{2p+1} \neq 0$, and we shall check the conditions of convergence for

$$(17) \sum_{p=0}^{+\infty} a_{2p+1} z^{2p+1},$$

where

$$a_{2p+1} = -(2p-1)a_{2p-1}, \quad p \in \mathbb{N}.$$

Assuming that $z \neq 0$, it follows by the criterion of quotients applied on (17) that the limiting value of

$$\left| \frac{a_{2p+1}z^{2p+1}}{a_{2p-1}z^{2p-1}} \right| = (2p-1)|z|^2$$

for $p \rightarrow +\infty$ must be smaller than 1 for the relevant z . This is only possible for $z = 0$, contradicting the assumption of $z \neq 0$.

Therefore, if $a_1 \neq 0$, the radius of convergence is 0. Since we are only interested in series of positive radius of convergence, it follows that $a_1 = 0$, and hence also $a_{2p+1} = 0$ for $p \in \mathbb{N}_0$, which together with $a_{2p} = 0$, $p \in \mathbb{N}$, found previously precisely gives us

$$a_n = 0 \quad \text{for } n \in \mathbb{N}.$$

We have proved that the only possibilities of Laurent series solutions necessarily must be of the form

$$f(z) = \sum_{n=0}^{+\infty} a_{-n}z^{-n} = \sum_{n=0}^{+\infty} b_n \cdot \frac{1}{z^n}, \quad b_n = a_{-n}, \quad n \in \mathbb{N}_0.$$

Replacing n by $-n$ in the recursion formula for a_n , we get

$$(-n-2)a_{-n-2} + a_{-n} = 0, \quad n \in \mathbb{N}_0,$$

and since $a_{-n-2} = b_{n+2}$ and $a_{-n} = b_n$, it follows that

$$b_{n+2} = \frac{1}{n+2} b_n, \quad n \in \mathbb{N}_0, \quad \text{or} \quad b_n = \frac{1}{n} b_{n-2}, \quad n \in \mathbb{N} \setminus \{1\}.$$

If $b_{n-2} \neq 0$ and $w = \frac{1}{z} \neq 0$, then

$$\left| \frac{b_n w^n}{b_{n-2} w^{n-2}} \right| = \frac{1}{n} |w|^2 \rightarrow 0 < 1 \quad \text{for } n \rightarrow +\infty,$$

for every $w \neq 0$, and the domain of convergence is given by

$$0 < |w| = \frac{1}{|z|} < +\infty.$$

The series is convergent for $z \in \mathbb{C} \setminus \{0\}$.

If $n = 2p$, $p \in \mathbb{N}$, is even, we get

$$(18) \quad 2p \cdot b_{2p} = b_{2(p-1)},$$

hence by a multiplication by $2^{p-1}(p-1)! \neq 0$, followed by a recursion,

$$2^p p! b_{2p} = 2^{p-1} \cdot (p-1)! b_{2(p-1)} = \cdots = 2^0 \cdot 0! b_0 = 1_0,$$

and thus

$$a_{-2p} = b_{2p} = \frac{1}{2^p p!} a_0, \quad p \in \mathbb{N}_0.$$

ALTERNATIVELY, it follows from (18) by a straight recursion that

$$b_{2p} = \frac{1}{2p} \cdot b_{2(p-1)} = \frac{1}{2p} \cdot \frac{1}{2(p-1)} \cdots \frac{1}{2 \cdot 2} \cdot \frac{1}{2 \cdot 1} b_0 = \frac{1}{2^p p!} a_0, \quad p \in \mathbb{N}_0.$$

If $n = 2p + 1$, $p \in \mathbb{N}$, is odd, then it follows by recursion that

$$b_{2p+1} = \frac{1}{2p+1} b_{2p-1} = \frac{1}{2p+1} \cdot \frac{1}{2p-1} \cdots \frac{1}{5} \cdot \frac{1}{3} \cdot b_1 = \frac{1}{(2p+1)(2p-1) \cdots 5 \cdot 3 \cdot 1} a_{-1}.$$

Remark 4.1 It is here possible further to reduce the expression by multiplying the numerator and the denominator by $2^p \cdot p! \neq 0$. This gives

$$b_{2p+1} = \frac{1}{2p+1} \cdot \frac{2p}{2p} \cdot \frac{1}{2p-1} \cdot \frac{2(p-1)}{2p-2} \cdot \frac{1}{2p-3} \cdots \frac{2 \cdot 2}{4} \cdot \frac{1}{3} \cdot \frac{2 \cdot 1}{2} \cdot \frac{1}{1} \cdot a_{-1} = \frac{2^p p!}{(2p+1)!} a_{-1}. \quad \diamond$$

Trust and responsibility

NNE and Pharmaplan have joined forces to create NNE Pharmaplan, the world's leading engineering and consultancy company focused entirely on the pharma and biotech industries.

Inés Aréizaga Esteva (Spain), 25 years old
Education: Chemical Engineer

– You have to be proactive and open-minded as a newcomer and make it clear to your colleagues what you are able to cope. The pharmaceutical field is new to me. But busy as they are, most of my colleagues find the time to teach me, and they also trust me. Even though it was a bit hard at first, I can feel over time that I am beginning to be taken seriously and that my contribution is appreciated.

Please click the advert



NNE Pharmaplan is the world's leading engineering and consultancy company focused entirely on the pharma and biotech industries. We employ more than 1500 people worldwide and offer global reach and local knowledge along with our all-encompassing list of services.
nnepharmaplan.com

nne pharmaplan®

Summing up, all Laurent series solutions, which are convergent for $z \in \mathbb{C} \setminus \{0\}$, are given by

$$\begin{aligned}
 f(z) &= \sum_{n=0}^{+\infty} a_{-n} \cdot \frac{1}{z^n} = \sum_{p=0}^{+\infty} b_{2p} \cdot \frac{1}{z^{2p}} + \sum_{p=0}^{+\infty} b_{2p+1} \cdot \frac{1}{z^{2p+1}} \\
 &= a_0 \sum_{n=0}^{+\infty} \frac{1}{n! 2^n} \cdot \frac{1}{z^{2n}} + a_{-1} \left\{ \frac{1}{z} + \sum_{p=1}^{+\infty} \frac{1}{(2p+1)(2p-1) \cdots 5 \cdot 3 \cdot 1} \cdot \frac{1}{z^{2p+1}} \right\} \\
 &= a_0 \sum_{n=0}^{+\infty} \frac{1}{n!} \left\{ \frac{1}{2z^2} \right\}^n + a_{-1} \sum_{n=0}^{+\infty} \frac{2^n n!}{(2n+1)!} \cdot \frac{1}{z^{2n+1}} \\
 &= a_0 \exp\left(\frac{1}{2z^2}\right) + a_{-1} \sum_{n=0}^{+\infty} \frac{2^n n!}{(2n+1)!} \cdot \frac{1}{z^{2n+1}}.
 \end{aligned}$$

Only the zero solution can be extended to all of \mathbb{C} .

The series expansion of $f_0(z)$ is convergent in $\mathbb{C} \setminus \{0\}$ (a neighbourhood of ∞), so the condition is that

$$a_{-1} = -\operatorname{res}(f_0; \infty) = 0,$$

so if $z \in \mathbb{C} \setminus \{0\}$, then

$$f_0(z) = a_0 \cdot \exp\left(\frac{1}{2z^2}\right).$$

Second method. *Transformation of the differential equation.* Since we shall prove that

$$a_n = 0 \quad \text{for } n \in \mathbb{N},$$

we shall actually prove that $f(z)$ has the structure

$$f(z) = \sum_{n=0}^{+\infty} a_{-n} \cdot \frac{1}{z^n} = \sum_{n=0}^{+\infty} b_n w^n = g(w), \quad w = \frac{1}{z}, \quad a_{-n} = b_n.$$

The idea is to transform (15) into an equivalent differential equation for $g(w)$. Since

$$\frac{dw}{dz} = \frac{d}{dz} \left\{ \frac{1}{z} \right\} = -\frac{1}{z^2} = -w^2,$$

it follows from the chain rule that

$$f'(z) = \frac{d}{dz} g(w) = g'(w) \frac{dw}{dz} = -w^2 g'(w) = -\frac{1}{z^2} g'(w),$$

and

$$f''(z) = \frac{2}{z^3} g'(w) - \frac{1}{z^2} g''(w) \frac{dw}{dz} = 2w^3 g'(w) + w^4 g''(w),$$

which we put into (15) for $z \neq 0$ and $w \neq 0$,

$$\begin{aligned} 0 &= z^4 f''(z) + (2z^3 + z) f'(z) - f(z) \\ &= \frac{1}{w^4} \{w^4 g''(w) + 2w^3 g'(w)\} + \left\{ \frac{2}{w^3} + \frac{1}{w} \right\} \cdot (-w^2 g'(w)) - g(w) \\ &= g''(w) + \frac{2}{w} g'(w) - \frac{2}{w} g'(w) - w g'(w) - g(w) = g''(w) - w g'(w) - g(w). \end{aligned}$$

The equation (15) is in the domain $\mathbb{C} \setminus \{0\}$ equivalent to

$$(19) \quad g''(w) - w g'(w) - g(w) = 0, \quad w \in \mathbb{C} \setminus \{0\},$$

where (19) of course can be extended to $w = 0$. (The restriction $w \neq 0$ is only caused by the transformation $w = \frac{1}{z}$.) Since (19) is a differential equation of analytic coefficients without singular points, (i.e. the coefficient of $g''(z)$ is $\neq 0$ everywhere), all solutions of (19) are *power series solutions* of domain of convergence \mathbb{C} , and there are precisely two linearly independent families of solutions. We conclude that $a_n = b_{-n} = 0$ for $n \in \mathbb{N}$.

Put

$$g(w) = \sum_{n=0}^{+\infty} b_n w^n, \quad g'(w) = \sum_{n=1}^{+\infty} n b_n w^{n-1}, \quad g''(w) = \sum_{n=2}^{+\infty} n(n-1) b_n w^{n-2}.$$

Then by insertion into (19),

$$0 = \sum_{n=2}^{+\infty} n(n-1) b_n w^{n-2} - \sum_{\substack{n=1 \\ (n=0)}}^{+\infty} n b_n w^n - \sum_{n=0}^{+\infty} b_n w^n = \sum_{n=0}^{+\infty} (n+2)(n+1) b_{n+2} w^n - \sum_{n=0}^{+\infty} (n+1) b_n w^n,$$

thus

$$\sum_{n=0}^{+\infty} (n+1) \{(n+2) b_{n+2} - b_n\} w^n = 0.$$

It follows from $n+1 \neq 0$ for $n \in \mathbb{N}_0$ and by the identity theorem that we have the following reduced recursion formula,

$$(n+2) b_{n+2} = b_n, \quad \text{thus} \quad b_{n+2} = \frac{1}{n+2} b_n, \quad n \in \mathbb{N}_0.$$

Then we proceed as in the **first method** above.

Third method. Inspection. Assume that $z \neq 0$. If we divide (15) by z^2 , we get by a small rearrangement that

$$0 = \{z^2 f''(z) + 2z f'(z)\} + \frac{z f'(z) - 1 \cdot f(z)}{z^2} = \frac{d}{dz} \{z^2 f'(z)\} + \frac{d}{dz} \left\{ \frac{f(z)}{z} \right\}.$$

Hence by an integration,

$$(20) \quad z^2 f'(z) + \frac{f(z)}{z} = c, \quad z \neq 0, \quad c \in \mathbb{C} \text{ arbitrary.}$$

When we put the Laurent series of $f(z)$ and $f'(z)$ into (20), then

$$c = \sum n a_n z^{n+1} + \sum a_n z^{n-1} = \sum (n-1) a_{n-1} z^n + \sum a_{n+1} z^n = \sum_{n=-\infty}^{+\infty} \{(n-1) a_{n-1} + a_{n+1}\} z^n.$$

Then we apply the identity theorem. We get in particular for $n = 0$,

$$-a_{-1} + a_1 = c.$$

However, c is an arbitrary constant, so this equation only says that a_{-1} and a_1 are independent of each other.

If $n \neq 0$, then

$$(n-1)a_{n-1} + a_{n+1} = 0, \quad n \in \mathbb{Z} \setminus \{0\},$$

which is a third variant of the recursion formula. This is with only trivial changes solved in the same way as by the **first method**.

Please click the advert

THE MILKWAY
LAUNCHING GRADUATE CAREERS

MILKROUND SYSTEM
Become a business star with internships, placements, graduate jobs & schemes from leading companies.
www.milkround.com

PLANET CAREER ADVICE
Inhabited by insights into business careers and orbited by application advice.

FIRST CONTACT
Get matched to top business employers via intelligent emails landing in your inbox.

Milkround.com: rated the #1 graduate recruitment website in the UK Graduate Careers Survey 2009 of 16,000 university finalists.

Milkround.com

Fourth method. *Transformation, followed by inspection.* We can also *inspect* the transformed differential equation (19). This gives

$$0 = g''(w) - w g'(w) - g(w) = \frac{d}{dw} \{g'(w) - w \cdot g(w)\},$$

hence by an integration,

$$g'(w) - w \cdot g(w) = c.$$

If $c = 0$, we get

$$g(w) = a \cdot \exp\left(\frac{w^2}{2}\right),$$

and if $c \neq 0$ we insert the series and solve the new recursion formula. The details are left to the reader.

Example 4.27 (a) Describe the type of all isolated singularities in $\mathbb{C}^* = \mathbb{C} \cup \{\infty\}$ of the function

$$f(z) = \frac{z^3 \exp\left(\frac{1}{z}\right)}{1+z}.$$

(b) Compute the line integral

$$\oint_{|z|=2} \frac{z^3 \exp\left(\frac{1}{z}\right)}{1+z} dz.$$

(a) We have clearly the three singularities $z = 0$, $z = -1$ and $z = \infty$, and no other.

Obviously, $z = 0$ is an *essential singularity* (see what happens when e.g. $z = x \rightarrow 0$ along the positive and the negative real half axis, respectively).

Furthermore, $z = -1$ is trivially a *simple pole*, and finally, $z = \infty$ is a *double pole*. The latter is seen in the following way:

$$\lim_{z \rightarrow \infty} \frac{f(z)}{z^2} = \lim_{z \rightarrow \infty} \frac{z}{1+z} \exp\left(\frac{1}{z}\right) = 1 \cdot e^0 = 1 \neq 0.$$

(b) Then by *Cauchy's residuum theorem*,

$$\begin{aligned} \oint_{|z|=2} \frac{z^3 \exp\left(\frac{1}{z}\right)}{1+z} dz &= - \oint_{|z|=2}^* \frac{z^3 \exp\left(\frac{1}{z}\right)}{1+z} dz = -2\pi i \cdot \operatorname{res} \left(\frac{z^3 \exp\left(\frac{1}{z}\right)}{1+z}; \infty \right) \\ &= 2\pi i \cdot \operatorname{res} \left(\frac{1}{z^2} \cdot \frac{1}{z^3} \exp z; 0 \right) = 2\pi i \cdot \operatorname{res} \left(\frac{1}{z^4} \cdot \frac{e^z}{z+1}; 0 \right) = 2\pi i \cdot \frac{1}{3!} \lim_{z \rightarrow 0} \frac{d^3}{dz^3} \left\{ \frac{e^z}{z+1} \right\} \\ &= \frac{\pi i}{3} \lim_{z \rightarrow 0} \frac{d^2}{dz^2} \left\{ \frac{e^z}{z+1} - \frac{e^z}{(z+1)^2} \right\} = \frac{\pi i}{3} \lim_{z \rightarrow 0} \frac{d}{dz} \left\{ \frac{e^z}{z+1} - 2 \cdot \frac{e^z}{(z+1)^2} + 2 \cdot \frac{e^z}{(z+1)^3} \right\} \\ &= \frac{\pi i}{3} \lim_{z \rightarrow 0} \left\{ \frac{e^z}{z+1} - 3 \frac{e^z}{(z+1)^2} + 6 \frac{e^z}{(z+1)^3} - 6 \frac{e^z}{(z+1)^4} \right\} = \frac{\pi i}{4} \{1 - 3 + 6 - 6\} = -\frac{2\pi i}{3}. \end{aligned}$$

ALTERNATIVELY,

$$\oint_{|z|=2} \frac{z^3 \exp\left(\frac{1}{z}\right)}{1+z} dz = 2\pi i \left\{ \operatorname{res} \left(\frac{z^3 \exp\left(\frac{1}{z}\right)}{1+z}; 0 \right) + \operatorname{res} \left(\frac{z^3 \exp\left(\frac{1}{z}\right)}{1+z}; -1 \right) \right\},$$

where

$$\operatorname{res} \left(\frac{z^3 \exp\left(\frac{1}{z}\right)}{1+z}; -1 \right) = (-1)^3 \exp\left(\frac{1}{-1}\right) = -\frac{1}{e},$$

because $z = -1$ is a simple pole.

Since $z = 0$ is an essential singularity, we must here find a_{-1} in the Laurent series expansion of $f(z)$ in $0 < |z| < 1$. We have in this domain,

$$\frac{z^3 \exp\left(\frac{1}{z}\right)}{1+z} = z^3 \sum_{k=0}^{+\infty} (-1)^k z^k \cdot \sum_{m=0}^{+\infty} \frac{1}{m!} \cdot \frac{1}{z^m} = \sum_{k=0}^{+\infty} \sum_{m=0}^{+\infty} \frac{(-1)^k}{m!} z^{3+k-m}.$$

It follows that we get a_{-1} for $3+k-m = -1$, i.e. when $m = k+4$, followed by a summation over k ,

$$\begin{aligned} \operatorname{res} \left(\frac{z^3 \exp\left(\frac{1}{z}\right)}{1+z}; 0 \right) &= a_{-1} = \sum_{k=0}^{+\infty} \frac{(-1)^k}{(k+4)!} = \sum_{n=4}^{+\infty} \frac{(-1)^n}{n!} = \frac{1}{e} - \left\{ 1 - \frac{1}{1!} + \frac{1}{2!} - \frac{1}{3!} \right\} \\ &= \frac{1}{e} - \left\{ \frac{1}{2} - \frac{1}{6} \right\} = \frac{1}{e} - \frac{1}{3}, \end{aligned}$$

and then by insertion,

$$\begin{aligned} \oint_{|z|=2} \frac{z^3 \exp\left(\frac{1}{z}\right)}{1+z} dz &= 2\pi i \left\{ \operatorname{res} \left(\frac{z^3 \exp\left(\frac{1}{z}\right)}{1+z}; 0 \right) + \operatorname{res} \left(\frac{z^3 \exp\left(\frac{1}{z}\right)}{1+z}; -1 \right) \right\} \\ &= 2\pi i \left\{ \frac{1}{e} - \frac{1}{3} - \frac{1}{e} \right\} = -\frac{2\pi i}{3}. \end{aligned}$$

Please click the advert



CHALLENGE YOURSELF

WWW.STUDYINSWEDEN.SE

Today's job market values ambitious, innovative, perceptive team players. Swedish universities foster these qualities through a forward-thinking culture where you're close to the latest ideas and global trends.

Whatever your career goals may be, studying in Sweden will give you valuable skills and a competitive advantage for your future. www.studyinsweden.se

Si.
Swedish Institute

Download free books at BookBooN.com

Example 4.28 Find the Laurent series expansion from $z = 1$ of

$$f(z) = \frac{z + 2}{(z - 1)^4(z + 3)},$$

in the domain given by $0 < |z - 1| < 4$.

Find the residuum of f at $z = 1$ and $z = \infty$.

First method. We get by the change of variable $w = z - 1$,

$$f(z) = g(w) = \frac{w + 3}{w^4(w + 4)} = \frac{1}{w^4} \left(1 - \frac{1}{w + 4} \right).$$

(a) If $0 < |z - 1| = |w| < 4$, then

$$\begin{aligned} f(z) &= \frac{1}{w^4} \left(1 - \frac{1}{4} \cdot \frac{1}{1 + \frac{w}{4}} \right) = \frac{1}{w^4} \left\{ 1 - \frac{1}{4} \sum_{n=0}^{+\infty} (-1)^n \cdot \left(\frac{w}{4} \right)^n \right\} \\ &= \frac{3}{4} \cdot \frac{1}{w^4} + \frac{1}{4^5} \sum_{n=1}^{+\infty} (-1)^{n+1} \cdot \left(\frac{w}{4} \right)^{n-4} = \frac{3}{4} \cdot \frac{1}{w^4} + \frac{1}{4^5} \sum_{n=-3}^{+\infty} (-1)^{n+1} \cdot \left(\frac{w}{4} \right)^n \\ &= \frac{3}{4} \cdot \frac{1}{(z-1)^4} + \frac{1}{4^5} \sum_{n=-3}^{+\infty} (-1)^{n+1} \left\{ \frac{1}{4(z-1)} \right\}^n. \end{aligned}$$

(b) If $|z - 1| = |w| > 4$, then we get instead

$$\begin{aligned} f(z) &= \frac{1}{w^4} \cdot \left(1 - \frac{1}{w} \cdot \frac{1}{1 + \frac{4}{w}} \right) = \frac{1}{w^4} \cdot \left\{ 1 - \frac{1}{w} \sum_{n=0}^{+\infty} (-1)^n \cdot \left(\frac{4}{w} \right)^n \right\} \\ &= \frac{1}{w^4} + \frac{1}{w^5} \sum_{n=0}^{+\infty} (-1)^{n+1} \cdot \left(\frac{4}{w} \right)^n = \frac{1}{w^4} + \frac{1}{4^5} \sum_{n=0}^{+\infty} (-1)^{n+1} \cdot \left(\frac{4}{w} \right)^{n+5} \\ &= \frac{1}{(z-1)^4} + \frac{1}{4^5} \sum_{n=5}^{+\infty} (-1)^n 4^n \cdot \frac{1}{(z-1)^n}. \end{aligned}$$

Second method. We use again the change of variable $w = z - 1$; but then we alternatively and more clumsy though also more realistic, decompose instead,

$$f(z) = \frac{w + 3}{w^4(w + 4)} = -\frac{1}{4^4} \cdot \frac{1}{w + 4} + \frac{1}{4^4} \cdot \frac{1}{w} - \frac{1}{4^3} \cdot \frac{1}{w^2} + \frac{1}{4^2} \cdot \frac{1}{w^3} + \frac{3}{4} \cdot \frac{1}{w^4}.$$

This decomposition is in itself difficult, so we only sketch the remaining part of the solution. We use the same method as above on

$$-\frac{1}{4^4} \cdot \frac{1}{w + 4},$$

for $0 < |w| < 4$, as well as for $|w| > 4$.

And then we get all the trouble of the final reductions.

Since $f(z)$ has a zero of order 4 at ∞ , we have

$$\operatorname{res}(f; \infty) = 0.$$

Furthermore, $z = -3$ is a simple pole, so

$$\operatorname{res}(f; -3) = \frac{-1}{(-4)^4} = -\frac{1}{256}.$$

The sum of the residues is zero,

$$\operatorname{res}(f; 1) + \operatorname{res}(f; -3) + \operatorname{res}(f; \infty) = 0,$$

hence

$$\operatorname{res}(f; 1) = \frac{1}{256}.$$

ALTERNATIVELY, $z = 1$ is a pole of order 4, hence by RULE I,

$$\begin{aligned} \operatorname{res}(f; 1) &= \frac{1}{3!} \lim_{z \rightarrow 1} \frac{d^3}{dz^3} \left(\frac{z+2}{z+3} \right) = \frac{1}{3!} \lim_{z \rightarrow 1} \frac{d^3}{dz^3} \left\{ 1 - \frac{1}{z+3} \right\} = \frac{1}{3!} \lim_{z \rightarrow 1} \frac{d^2}{dz^2} \left\{ \frac{1}{(z+3)^2} \right\} \\ &= \frac{1}{3!} \lim_{z \rightarrow 1} \frac{d}{dz} \left\{ -\frac{2}{(z+3)^3} \right\} = \frac{1}{3!} \lim_{z \rightarrow 1} \frac{2 \cdot 3}{(z+3)^4} = \frac{1}{4^4} = \frac{1}{256}. \end{aligned}$$

Please click the advert



DIVERSE - INNOVATIVE - INTERNATIONAL

Are you considering a European business degree?

Copenhagen Business School is one of the largest business schools in Northern Europe with more than 15,000 students from Europe, North America, Australia and Asia.

Are you curious to know how a modern European business school competes with a diverse, innovative and international study environment?

Please visit Copenhagen Business School at www.cbs.dk



Copenhagen Business School
HANDELSHØJSKOLEN

Diversity creating knowledge

